

Trapezgewindespindeln

Lead Screws

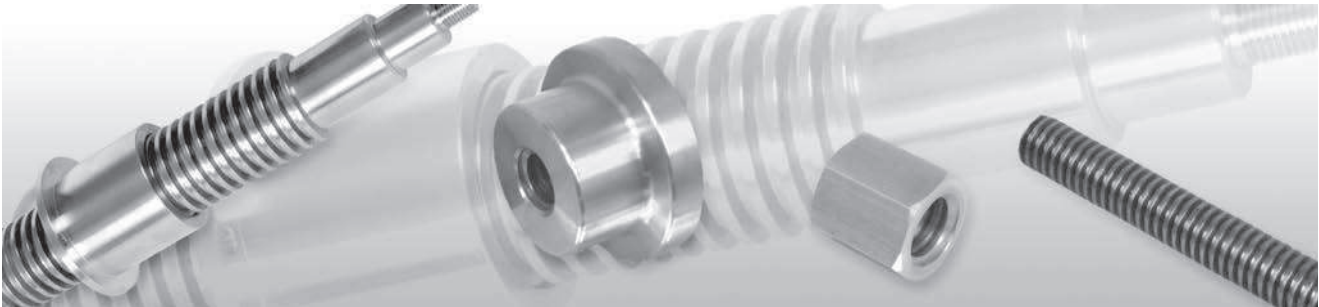

Lagerprogramm

Trapezgewindespindel gerollt rechts / links
 Trapezgewindespindel gewirbelt rechts / links
 Trapezgewindespindel rostfrei, gerollt rechts
 Trapezgewindespindel rostfrei, gewirbelt rechts
 Trapezgewindemuttern rechts / links
 Spindelendenbearbeitung für Lagervorrichtungen
 Lagervorrichtungen (Stehlager & Flanschlager)

F 1 - F 2
 F 3 - F 4
 F 5
 F 6
 F 7 - F 10
 F 12 - F 13
 F 14 - F 18

stock programme

Lead screws rolled finish right hand / left hand
 Lead screws whirled finish right hand / left hand
 Lead screws stainless steel, rolled finish, right hand
 Lead screws stainless steel, whirled finish, right hand
 Threaded nuts right hand / left hand
 Lead screw Machining for Lead screw Support Units
 Lead screw Support Units (Pedestal & Flange)



Sonderanfertigungen

Auf Anfrage

Trapezgewindespindeln und Trapezgewindemuttern

einbaufertig bearbeitet, gerollt, gewirbelt oder
 geschliffen nach Ihren Wünschen;
 max. Spindellänge 12 000 mm

made to order

on request

lead screws and threaded nuts

ready to be installed, machined, whirled or ground
 to your order;
 max. screw length 12 000 mm



Trapezgewindespindeln - gerollt rechtsgängig

Lead Screws - Rolled Finish, Right Hand



Tr d x p	d ₂ min	d ₂ max	d ₃ min	L	[kg]	Bestell-Nr. Part No.
12 x 3	10,191	10,415	7,8	1 000	0,75	500-012-010
12 x 3	10,191	10,415	7,8	2 000	1,50	500-012-020
12 x 3	10,191	10,415	7,8	3 000	2,25	500-012-030
14 x 3	12,191	12,415	9,8	1 000	1,04	500-014-010
14 x 3	12,191	12,415	9,8	2 000	2,08	500-014-020
14 x 3	12,191	12,415	9,8	3 000	3,12	500-014-030
16 x 4	13,640	13,905	10,8	1 000	1,20	500-016-010
16 x 4	13,640	13,905	10,8	2 000	2,40	500-016-020
16 x 4	13,640	13,905	10,8	3 000	3,60	500-016-030
18 x 4	15,640	15,905	12,8	1 000	1,58	500-018-010
18 x 4	15,640	15,905	12,8	2 000	3,16	500-018-020
18 x 4	15,640	15,905	12,8	3 000	4,74	500-018-030
20 x 4	17,640	17,905	14,8	1 000	2,00	500-020-010
20 x 4	17,640	17,905	14,8	2 000	4,00	500-020-020
20 x 4	17,640	17,905	14,8	3 000	6,00	500-020-030
22 x 5	19,114	19,394	15,5	1 000	2,23	500-022-010
22 x 5	19,114	19,394	15,5	2 000	4,46	500-022-020
22 x 5	19,114	19,394	15,5	3 000	6,69	500-022-030
24 x 5	21,094	21,394	17,5	1 000	2,70	500-024-010
24 x 5	21,094	21,394	17,5	2 000	5,40	500-024-020
24 x 5	21,094	21,394	17,5	3 000	8,10	500-024-030
26 x 5	23,094	23,394	19,5	1 000	3,26	500-026-010
26 x 5	23,094	23,394	19,5	2 000	6,52	500-026-020
26 x 5	23,094	23,394	19,5	3 000	9,78	500-026-030
28 x 5	25,094	25,394	21,5	1 000	3,85	500-028-010
28 x 5	25,094	25,394	21,5	2 000	7,70	500-028-020
28 x 5	25,094	25,394	21,5	3 000	11,55	500-028-030
30 x 6	26,547	26,882	21,9	1 000	4,50	500-030-010
30 x 6	26,547	26,882	21,9	2 000	9,00	500-030-020
30 x 6	26,547	26,882	21,9	3 000	13,50	500-030-030
32 x 6	28,547	28,882	23,9	1 000	5,18	500-032-010
32 x 6	28,547	28,882	23,9	2 000	10,36	500-032-020
32 x 6	28,547	28,882	23,9	3 000	15,54	500-032-030
36 x 6	32,547	32,882	27,9	1 000	6,70	500-036-010
36 x 6	32,547	32,882	27,9	2 000	13,40	500-036-020
36 x 6	32,547	32,882	27,9	3 000	20,10	500-036-030
40 x 7	36,020	36,375	30,5	1 000	8,00	500-040-010
40 x 7	36,020	36,375	30,5	2 000	16,00	500-040-020
40 x 7	36,020	36,375	30,5	3 000	24,00	500-040-030
44 x 7	40,020	40,375	34,5	1 000	9,87	500-044-010
44 x 7	40,020	40,375	34,5	2 000	19,74	500-044-020
44 x 7	40,020	40,375	34,5	3 000	29,61	500-044-030
48 x 8	43,468	43,868	37,8	1 000	11,95	500-048-010
48 x 8	43,468	43,868	37,8	2 000	23,90	500-048-020
48 x 8	43,468	43,868	37,8	3 000	35,85	500-048-030
50 x 8	45,468	45,868	39,3	1 000	13,00	500-050-010
50 x 8	45,468	45,868	39,3	2 000	26,00	500-050-020
50 x 8	45,468	45,868	39,3	3 000	39,00	500-050-030
60 x 9	54,935	55,360	48,1	1 000	18,00	500-060-010
60 x 9	54,935	55,360	48,1	2 000	36,00	500-060-020
60 x 9	54,935	55,360	48,1	3 000	54,00	500-060-030

Trapezgewindespindeln - gerollt, linksgängig

Lead Screws - Rolled Finish, Left Hand

DIN | DIN

 Qualität | quality
 Material | material

103
7e
1.0501 [C35]

Tr d x p	d ₂ min	d ₂ max	d ₃ min	L	[kg]	Bestell-Nr. Part No.
12 x 3	10,191	10,415	7,8	1 000	0,75	505-012-010
12 x 3	10,191	10,415	7,8	2 000	1,50	505-012-020
12 x 3	10,191	10,415	7,8	3 000	2,25	505-012-030
14 x 3	12,191	12,415	9,8	1 000	1,04	505-014-010
14 x 3	12,191	12,415	9,8	2 000	2,08	505-014-020
14 x 3	12,191	12,415	9,8	3 000	3,12	505-014-030
16 x 4	13,640	13,905	10,8	1 000	1,20	505-016-010
16 x 4	13,640	13,905	10,8	2 000	2,40	505-016-020
16 x 4	13,640	13,905	10,8	3 000	3,60	505-016-030
18 x 4	15,640	15,905	12,8	1 000	1,58	505-018-010
18 x 4	15,640	15,905	12,8	2 000	3,16	505-018-020
18 x 4	15,640	15,905	12,8	3 000	4,74	505-018-030
20 x 4	17,640	17,905	14,8	1 000	2,00	505-020-010
20 x 4	17,640	17,905	14,8	2 000	4,00	505-020-020
20 x 4	17,640	17,905	14,8	3 000	6,00	505-020-030
22 x 5	19,114	19,394	15,5	1 000	2,23	505-022-010
22 x 5	19,114	19,394	15,5	2 000	4,46	505-022-020
22 x 5	19,114	19,394	15,5	3 000	6,69	505-022-030
24 x 5	21,094	21,394	17,5	1 000	2,70	505-024-010
24 x 5	21,094	21,394	17,5	2 000	5,40	505-024-020
24 x 5	21,094	21,394	17,5	3 000	8,10	505-024-030
26 x 5	23,094	23,394	19,5	1 000	3,26	505-026-010
26 x 5	23,094	23,394	19,5	2 000	6,52	505-026-020
26 x 5	23,094	23,394	19,5	3 000	9,78	505-026-030
28 x 5	25,094	25,394	21,5	1 000	3,85	505-028-010
28 x 5	25,094	25,394	21,5	2 000	7,70	505-028-020
28 x 5	25,094	25,394	21,5	3 000	11,55	505-028-030
30 x 6	26,547	26,882	21,9	1 000	4,50	505-030-010
30 x 6	26,547	26,882	21,9	2 000	9,00	505-030-020
30 x 6	26,547	26,882	21,9	3 000	13,50	505-030-030
32 x 6	28,547	28,882	23,9	1 000	5,18	505-032-010
32 x 6	28,547	28,882	23,9	2 000	10,36	505-032-020
32 x 6	28,547	28,882	23,9	3 000	15,54	505-032-030
36 x 6	32,547	32,882	27,9	1 000	6,70	505-036-010
36 x 6	32,547	32,882	27,9	2 000	13,40	505-036-020
36 x 6	32,547	32,882	27,9	3 000	20,10	505-036-030
40 x 7	36,020	36,375	30,5	1 000	8,00	505-040-010
40 x 7	36,020	36,375	30,5	2 000	16,00	505-040-020
40 x 7	36,020	36,375	30,5	3 000	24,00	505-040-030
44 x 7	40,020	40,375	34,5	1 000	9,87	505-044-010
44 x 7	40,020	40,375	34,5	2 000	19,74	505-044-020
44 x 7	40,020	40,375	34,5	3 000	29,61	505-044-030
48 x 8	43,468	43,868	37,8	1 000	11,95	505-048-010
48 x 8	43,468	43,868	37,8	2 000	23,90	505-048-020
48 x 8	43,468	43,868	37,8	3 000	35,85	505-048-030
50 x 8	45,468	45,868	39,3	1 000	13,00	505-050-010
50 x 8	45,468	45,868	39,3	2 000	26,00	505-050-020
50 x 8	45,468	45,868	39,3	3 000	39,00	505-050-030
60 x 9	54,935	55,360	48,1	1 000	18,00	505-060-010
60 x 9	54,935	55,360	48,1	2 000	36,00	505-060-020
60 x 9	54,935	55,360	48,1	3 000	54,00	505-060-030

Trapezgewindespindeln - gewirbelt, rechtsgängig

Lead Screws - Whirled Finish, Right Hand



Tr d x p	d ₂ min	d ₂ max	d ₃ min	L	[kg]	Bestell-Nr. Part No.
10 x 3	8,191	8,415	6,14	1 000	0,45	501-010-010
10 x 3	8,191	8,415	6,14	2 000	0,90	501-010-020
10 x 3	8,191	8,415	6,14	3 000	1,35	501-010-030
12 x 3	10,191	10,415	8,14	1 000	0,75	501-012-010
12 x 3	10,191	10,415	8,14	2 000	1,50	501-012-020
12 x 3	10,191	10,415	8,14	3 000	2,25	501-012-030
14 x 3	12,191	12,415	10,14	1 000	0,96	501-014-010
14 x 3	12,191	12,415	10,14	2 000	1,92	501-014-020
14 x 3	12,191	12,415	10,14	3 000	2,88	501-014-030
16 x 4	13,640	13,905	11,07	1 000	1,20	501-016-010
16 x 4	13,640	13,905	11,07	2 000	2,40	501-016-020
16 x 4	13,640	13,905	11,07	3 000	3,60	501-016-030
18 x 4	15,640	15,905	13,07	1 000	1,58	501-018-010
18 x 4	15,640	15,905	13,07	2 000	3,16	501-018-020
18 x 4	15,640	15,905	13,07	3 000	4,74	501-018-030
20 x 4	17,640	17,905	15,18	1 000	2,00	501-020-010
20 x 4	17,640	17,905	15,18	2 000	4,00	501-020-020
20 x 4	17,640	17,905	15,18	3 000	6,00	501-020-030
22 x 5	19,114	19,394	16,04	1 000	2,35	501-022-010
22 x 5	19,114	19,394	16,04	2 000	4,70	501-022-020
22 x 5	19,114	19,394	16,04	3 000	7,05	501-022-030
24 x 5	21,094	21,394	18,02	1 000	2,70	501-024-010
24 x 5	21,094	21,394	18,02	2 000	5,40	501-024-020
24 x 5	21,094	21,394	18,02	3 000	8,10	501-024-030
26 x 5	23,094	23,394	20,02	1 000	3,26	501-026-010
26 x 5	23,094	23,394	20,02	2 000	6,52	501-026-020
26 x 5	23,094	23,394	20,02	3 000	9,78	501-026-030
28 x 5	25,094	25,394	22,02	1 000	3,85	501-028-010
28 x 5	25,094	25,394	22,02	2 000	7,70	501-028-020
28 x 5	25,094	25,394	22,02	3 000	11,55	501-028-030
30 x 6	26,547	26,882	22,46	1 000	4,50	501-030-010
30 x 6	26,547	26,882	22,46	2 000	9,00	501-030-020
30 x 6	26,547	26,882	22,46	3 000	13,50	501-030-030
32 x 6	28,547	28,882	24,46	1 000	5,13	501-032-010
32 x 6	28,547	28,882	24,46	2 000	10,26	501-032-020
32 x 6	28,547	28,882	24,46	3 000	15,39	501-032-030
36 x 6	32,547	32,882	28,46	1 000	6,70	501-036-010
36 x 6	32,547	32,882	28,46	2 000	13,40	501-036-020
36 x 6	32,547	32,882	28,46	3 000	20,10	501-036-030
40 x 7	36,020	36,375	31,43	1 000	8,00	501-040-010
40 x 7	36,020	36,375	31,43	2 000	16,00	501-040-020
40 x 7	36,020	36,375	31,43	3 000	24,00	501-040-030
44 x 7	40,020	40,375	35,43	1 000	9,87	501-044-010
44 x 7	40,020	40,375	35,43	2 000	19,74	501-044-020
44 x 7	40,020	40,375	35,43	3 000	29,61	501-044-030
48 x 8	43,468	43,868	38,37	1 000	11,95	501-048-010
48 x 8	43,468	43,868	38,37	2 000	23,90	501-048-020
48 x 8	43,468	43,868	38,37	3 000	35,85	501-048-030
50 x 8	45,468	45,868	40,37	1 000	13,00	501-050-010
50 x 8	45,468	45,868	40,37	2 000	26,00	501-050-020
50 x 8	45,468	45,868	40,37	3 000	39,00	501-050-030
60 x 9	54,935	55,360	49,33	1 000	18,00	501-060-010
60 x 9	54,935	55,360	49,33	2 000	36,00	501-060-020
60 x 9	54,935	55,360	49,33	3 000	54,00	501-060-030
70 x 10	64,425	64,850	58,32	1 000	26,00	501-070-010
70 x 10	64,425	64,850	58,32	2 000	52,00	501-070-020
70 x 10	64,425	64,850	58,32	3 000	78,00	501-070-030

Trapezgewindespindeln - gewirbelt, linksgängig

Lead Screws - Whirled Finish, Left Hand



Tr d x p	d ₂ min	d ₂ max	d ₃ min	L	[kg]	Bestell-Nr. Part No.
10 x 3	8,191	8,415	6,14	1 000	0,45	506-010-010
10 x 3	8,191	8,415	6,14	2 000	0,90	506-010-020
10 x 3	8,191	8,415	6,14	3 000	1,35	506-010-030
12 x 3	10,191	10,415	8,14	1 000	0,75	506-012-010
12 x 3	10,191	10,415	8,14	2 000	1,50	506-012-020
12 x 3	10,191	10,415	8,14	3 000	2,25	506-012-030
14 x 3	12,191	12,415	10,14	1 000	0,96	506-014-010
14 x 3	12,191	12,415	10,14	2 000	1,92	506-014-020
14 x 3	12,191	12,415	10,14	3 000	2,88	506-014-030
16 x 4	13,640	13,905	11,07	1 000	1,20	506-016-010
16 x 4	13,640	13,905	11,07	2 000	2,40	506-016-020
16 x 4	13,640	13,905	11,07	3 000	3,60	506-016-030
18 x 4	15,640	15,905	13,07	1 000	1,58	506-018-010
18 x 4	15,640	15,905	13,07	2 000	3,16	506-018-020
18 x 4	15,640	15,905	13,07	3 000	4,74	506-018-030
20 x 4	17,640	17,905	15,18	1 000	2,00	506-020-010
20 x 4	17,640	17,905	15,18	2 000	4,00	506-020-020
20 x 4	17,640	17,905	15,18	3 000	6,00	506-020-030
22 x 5	19,114	19,394	16,04	1 000	2,35	506-022-010
22 x 5	19,114	19,394	16,04	2 000	4,70	506-022-020
22 x 5	19,114	19,394	16,04	3 000	7,05	506-022-030
24 x 5	21,094	21,394	18,02	1 000	2,70	506-024-010
24 x 5	21,094	21,394	18,02	2 000	5,40	506-024-020
24 x 5	21,094	21,394	18,02	3 000	8,10	506-024-030
26 x 5	23,094	23,394	20,02	1 000	3,26	506-026-010
26 x 5	23,094	23,394	20,02	2 000	6,52	506-026-020
26 x 5	23,094	23,394	20,02	3 000	9,78	506-026-030
28 x 5	25,094	25,394	22,02	1 000	3,85	506-028-010
28 x 5	25,094	25,394	22,02	2 000	7,70	506-028-020
28 x 5	25,094	25,394	22,02	3 000	11,55	506-028-030
30 x 6	26,547	26,882	22,46	1 000	4,50	506-030-010
30 x 6	26,547	26,882	22,46	2 000	9,00	506-030-020
30 x 6	26,547	26,882	22,46	3 000	13,50	506-030-030
32 x 6	28,547	28,882	24,46	1 000	5,13	506-032-010
32 x 6	28,547	28,882	24,46	2 000	10,26	506-032-020
32 x 6	28,547	28,882	24,46	3 000	15,39	506-032-030
36 x 6	32,547	32,882	28,46	1 000	6,70	506-036-010
36 x 6	32,547	32,882	28,46	2 000	13,40	506-036-020
36 x 6	32,547	32,882	28,46	3 000	20,10	506-036-030
40 x 7	36,020	36,375	31,43	1 000	8,00	506-040-010
40 x 7	36,020	36,375	31,43	2 000	16,00	506-040-020
40 x 7	36,020	36,375	31,43	3 000	24,00	506-040-030
44 x 7	40,020	40,375	35,43	1 000	9,87	506-044-010
44 x 7	40,020	40,375	35,43	2 000	19,74	506-044-020
44 x 7	40,020	40,375	35,43	3 000	29,61	506-044-030
48 x 8	43,468	43,868	38,37	1 000	11,95	506-048-010
48 x 8	43,468	43,868	38,37	2 000	23,90	506-048-020
48 x 8	43,468	43,868	38,37	3 000	35,85	506-048-030
50 x 8	45,468	45,868	40,37	1 000	13,00	506-050-010
50 x 8	45,468	45,868	40,37	2 000	26,00	506-050-020
50 x 8	45,468	45,868	40,37	3 000	39,00	506-050-030
60 x 9	54,935	55,360	49,33	1 000	18,00	506-060-010
60 x 9	54,935	55,360	49,33	2 000	36,00	506-060-020
60 x 9	54,935	55,360	49,33	3 000	54,00	506-060-030
70 x 10	64,425	64,850	58,32	1 000	26,00	506-070-010
70 x 10	64,425	64,850	58,32	2 000	52,00	506-070-020
70 x 10	64,425	64,850	58,32	3 000	78,00	506-070-030

Rostfreie Trapezgewindespindeln - gerollt, rechtsgängig

Stainless Steel Lead Screws - Rolled Finish, Right Hand

Tr d x p	d₂ min	d₂ max	d₃ min	L	[kg]	Bestell-Nr. Part No.
12 x 3	10,191	10,415	7,8	1 000	0,75	500-012-210
12 x 3	10,191	10,415	7,8	2 000	1,50	500-012-220
12 x 3	10,191	10,415	7,8	3 000	2,25	500-012-230
16 x 4	13,640	13,905	10,8	1 000	1,20	500-016-210
16 x 4	13,640	13,905	10,8	2 000	2,40	500-016-220
16 x 4	13,640	13,905	10,8	3 000	3,60	500-016-230
18 x 4	15,640	15,905	12,8	1 000	1,58	500-018-210
18 x 4	15,640	15,905	12,8	2 000	3,16	500-018-220
18 x 4	15,640	15,905	12,8	3 000	4,74	500-018-230
20 x 4	17,640	17,905	14,8	1 000	2,00	500-020-210
20 x 4	17,640	17,905	14,8	2 000	4,00	500-020-220
20 x 4	17,640	17,905	14,8	3 000	6,00	500-020-230
24 x 5	21,094	21,394	17,5	1 000	2,70	500-024-210
24 x 5	21,094	21,394	17,5	2 000	5,40	500-024-220
24 x 5	21,094	21,394	17,5	3 000	8,10	500-024-230
26 x 5	23,094	23,394	19,5	1 000	3,26	500-026-210
26 x 5	23,094	23,394	19,5	2 000	6,52	500-026-220
26 x 5	23,094	23,394	19,5	3 000	9,78	500-026-230
28 x 5	25,094	25,394	21,5	1 000	3,85	500-028-210
28 x 5	25,094	25,394	21,5	2 000	7,70	500-028-220
28 x 5	25,094	25,394	21,5	3 000	11,55	500-028-230
30 x 6	26,547	26,882	21,9	1 000	4,50	500-030-210
30 x 6	26,547	26,882	21,9	2 000	9,00	500-030-220
30 x 6	26,547	26,882	21,9	3 000	13,50	500-030-230
32 x 6	28,547	28,882	23,9	1 000	5,18	500-032-210
32 x 6	28,547	28,882	23,9	2 000	10,36	500-032-220
32 x 6	28,547	28,882	23,9	3 000	15,54	500-032-230
36 x 6	32,547	32,882	27,9	1 000	6,70	500-036-210
36 x 6	32,547	32,882	27,9	2 000	13,40	500-036-220
36 x 6	32,547	32,882	27,9	3 000	20,10	500-036-230
40 x 7	36,020	36,375	30,5	1 000	8,00	500-040-210
40 x 7	36,020	36,375	30,5	2 000	16,00	500-040-220
40 x 7	36,020	36,375	30,5	3 000	24,00	500-040-230
50 x 8	45,468	45,868	39,3	1 000	13,00	500-050-210
50 x 8	45,468	45,868	39,3	2 000	26,00	500-050-220
50 x 8	45,468	45,868	39,3	3 000	39,00	500-050-230

Rostfreie Trapezgewindespindeln - gewirbelt, rechtsgängig

Stainless Steel Lead Screws - Whirled Finish, Right Hand

Tr d x p	d ₂ min	d ₂ max	d ₃ min	L	[kg]	Bestell-Nr. Part No.
12 x 3	10,191	10,415	8,14	1 000	0,75	501-012-210
12 x 3	10,191	10,415	8,14	2 000	1,50	501-012-220
12 x 3	10,191	10,415	8,14	3 000	2,25	501-012-230
16 x 4	13,640	13,905	11,07	1 000	1,20	501-016-210
16 x 4	13,640	13,905	11,07	2 000	2,40	501-016-220
16 x 4	13,640	13,905	11,07	3 000	3,60	501-016-230
18 x 4	15,640	15,905	13,07	1 000	1,58	501-018-210
18 x 4	15,640	15,905	13,07	2 000	3,16	501-018-220
18 x 4	15,640	15,905	13,07	3 000	4,74	501-018-230
20 x 4	17,640	17,905	15,18	1 000	2,00	501-020-210
20 x 4	17,640	17,905	15,18	2 000	4,00	501-020-220
20 x 4	17,640	17,905	15,18	3 000	6,00	501-020-230
24 x 5	21,094	21,394	18,02	1 000	2,70	501-024-210
24 x 5	21,094	21,394	18,02	2 000	5,40	501-024-220
24 x 5	21,094	21,394	18,02	3 000	8,10	501-024-230
26 x 5	23,094	23,394	20,02	1 000	3,26	501-026-210
26 x 5	23,094	23,394	20,02	2 000	6,52	501-026-220
26 x 5	23,094	23,394	20,02	3 000	9,78	501-026-230
28 x 5	25,094	25,394	22,02	1 000	3,85	501-028-210
28 x 5	25,094	25,394	22,02	2 000	7,70	501-028-220
28 x 5	25,094	25,394	22,02	3 000	11,55	501-028-230
30 x 6	26,547	26,882	22,46	1 000	4,50	501-030-210
30 x 6	26,547	26,882	22,46	2 000	9,00	501-030-220
30 x 6	26,547	26,882	22,46	3 000	13,50	501-030-230
32 x 6	28,547	28,882	24,46	1 000	5,18	501-032-210
32 x 6	28,547	28,882	24,46	2 000	10,36	501-032-220
32 x 6	28,547	28,882	24,46	3 000	15,54	501-032-230
36 x 6	32,547	32,882	28,46	1 000	6,70	501-036-210
36 x 6	32,547	32,882	28,46	2 000	13,40	501-036-220
36 x 6	32,547	32,882	28,46	3 000	20,10	501-036-230
40 x 7	36,020	36,375	31,43	1 000	8,00	501-040-210
40 x 7	36,020	36,375	31,43	2 000	16,00	501-040-220
40 x 7	36,020	36,375	31,43	3 000	24,00	501-040-230
50 x 8	45,468	45,868	40,37	1 000	13,00	501-050-210
50 x 8	45,468	45,868	40,37	2 000	26,00	501-050-220
50 x 8	45,468	45,868	40,37	3 000	39,00	501-050-230

Trapezgewindemuttern - rechtsgängig

Threaded Nuts - Right Hand

Gewindemuttern-Rohlinge, rund			cast finish, round					
Tr d x p	d _a	L	Bestell-Nr.				Part No.	
			● 1.0715 [9 S Mn 28 K] St	● PETP synt. mat.	● GG 25 cast iron	● Rg 7 Bronze	L	● 1.0715 [9 S Mn 28 K] St
10 x 3	22	20	511-010-100		511-010-500	511-010-600	15	511-010-110
12 x 3	26	24	511-012-100	511-012-800	511-012-500	511-012-600	18	511-012-110
14 x 3	30	28	511-014-100		511-014-500	511-014-600	21	511-014-110
16 x 4	36	32	511-016-100	511-016-800	511-016-500	511-016-600	24	511-016-110
18 x 4	40	36	511-018-100		511-018-500	511-018-600	27	511-018-110
20 x 4	45	40	511-020-100	511-020-800	511-020-500	511-020-600	30	511-020-110
22 x 5	45	44	511-022-100		511-022-500	511-022-600	33	511-022-110
24 x 5	50	48	511-024-100	511-024-800	511-024-500	511-024-600	36	511-024-110
26 x 5	55	52	511-026-100		511-026-500	511-026-600	39	511-026-110
28 x 5	60	56	511-028-100		511-028-500	511-028-600	42	511-028-110
30 x 6	60	60	511-030-100	511-030-800	511-030-500	511-030-600	45	511-030-110
32 x 6	60	64	511-032-100		511-032-500	511-032-600	48	511-032-110
36 x 6	75	72	511-036-100	511-036-800	511-036-500	511-036-600	54	511-036-110
40 x 7	80	80	511-040-100	511-040-800	511-040-500	511-040-600	60	511-040-110
44 x 7	80	88	511-044-100		511-044-500	511-044-600	66	511-044-110
48 x 8	90	96	511-048-100		511-048-500	511-048-600	72	511-048-110
50 x 8	90	100	511-050-100	511-050-800	511-050-500	511-050-600	75	511-050-110
60 x 9	100	120	511-060-100		511-060-500	511-060-600	90	511-060-110
70 x 10	110	140	511-070-100		511-070-500	511-070-600	105	511-070-110

Trapezgewindemuttern - rechtsgängig

Threaded Nuts - Right Hand

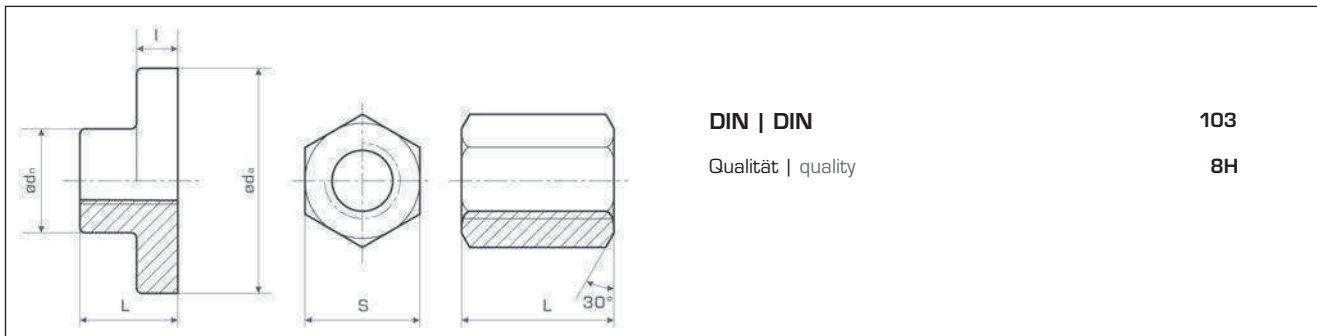

Gewindemuttern-Rohlinge

cast finish

Tr d x p	L	l	d _a	d _n	Flansch flange		L	S	sechskant hexagonal
					Bestell-Nr.				Part No.
					GG 25 cast iron	Rg 7 Bronze			1.0715 [9 S Mn 28 K] St
10 x 3	15	6	35	20	511-010-570	511-010-670	15	17	511-010-150
12 x 3	20	7	42	24	511-012-570	511-012-670	18	19	511-012-150
14 x 3	24	10	52	30	511-014-570	511-014-670	21	22	511-014-150
16 x 4	24	10	52	30	511-016-570	511-016-670	24	27	511-016-150
18 x 4	26	11	62	38	511-018-570	511-018-670	27	27	511-018-150
20 x 4	26	11	62	38	511-020-570	511-020-670	30	30	511-020-150
22 x 5	33	13	77	50	511-022-570	511-022-670	33	32	511-022-150
24 x 5	33	13	77	50	511-024-570	511-024-670	36	36	511-024-150
26 x 5	33	13	77	50	511-026-570	511-026-670	42	41	511-026-150
28 x 5	48	15	90	58	511-028-570	511-028-670	42	41	511-028-150
30 x 6	48	15	90	58	511-030-570	511-030-670	45	46	511-030-150
32 x 6	60	20	115	80	511-032-570	511-032-670	48	46	511-032-150
36 x 6	60	20	115	80	511-036-570	511-036-670	54	55	511-036-150
40 x 7	65	20	140	80	511-040-570	511-040-670	60	65	511-040-150
44 x 7	65	20	140	80	511-044-570	511-044-670	66	65	511-044-150
48 x 8	70	20	170	90	511-048-570	511-048-670	72	75	511-048-150
50 x 8	70	20	170	90	511-050-570	511-050-670	75	75	511-050-150
60 x 9							90	90	511-060-150
70 x 10							105	90	511-070-150

Trapezgewindemuttern - linksgängig

Threaded Nuts - Left Hand



Gewindemuttern-Rohlinge, rund			cast finish, round				
$\frac{Tr}{d \times p}$	d_a	L	Bestell-Nr.			Part No.	
			● 1.0715 [9 S Mn 28 K] St	● GG 25 cast iron	● Rg 7 Bronze	L	● 1.0715 [9 S Mn 28 K] St
10 x 3	22	20	516-010-100	516-010-500	516-010-600	15	516-010-110
12 x 3	26	24	516-012-100	516-012-500	516-012-600	18	516-012-110
14 x 3	30	28	516-014-100	516-014-500	516-014-600	21	516-014-110
16 x 4	36	32	516-016-100	516-016-500	516-016-600	24	516-016-110
18 x 4	40	36	516-018-100	516-018-500	516-018-600	27	516-018-110
20 x 4	45	40	516-020-100	516-020-500	516-020-600	30	516-020-110
22 x 5	45	44	516-022-100	516-022-500	516-022-600	33	516-022-110
24 x 5	50	48	516-024-100	516-024-500	516-024-600	36	516-024-110
26 x 5	55	52	516-026-100	516-026-500	516-026-600	39	516-026-110
28 x 5	60	56	516-028-100	516-028-500	516-028-600	42	516-028-110
30 x 6	60	60	516-030-100	516-030-500	516-030-600	45	516-030-110
32 x 6	60	64	516-032-100	516-032-500	516-032-600	48	516-032-110
36 x 6	75	72	516-036-100	516-036-500	516-036-600	54	516-036-110
40 x 7	80	80	516-040-100	516-040-500	516-040-600	60	516-040-110
44 x 7	80	88	516-044-100	516-044-500	516-044-600	66	516-044-110
48 x 8	90	96	516-048-100	516-048-500	516-048-600	72	516-048-110
50 x 8	90	100	516-050-100	516-050-500	516-050-600	75	516-050-110
60 x 9	100	120	516-060-100	516-060-500	516-060-600	90	516-060-110
70 x 10	110	140	516-070-100	516-070-500	516-070-600	105	516-070-110

Trapezgewindemuttern - linksgängig

Threaded Nuts - Left Hand

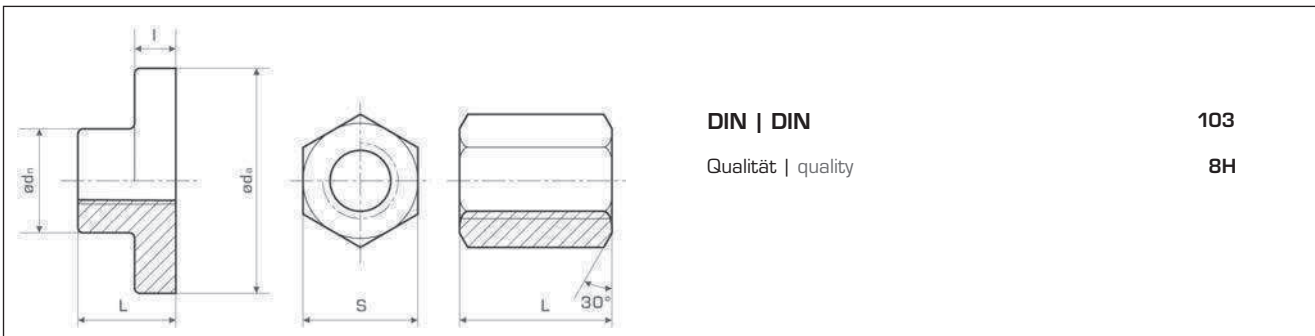

Gewindemuttern-Rohlinge

cast finish

Tr d x p	L	l	d _a	d _n	Flansch flange Bestell-Nr.		L	S	sechskant hexagonal Part No.
					GG 25 cast iron	Rg 7 Bronze			1.0715 [9 S Mn 28 K] St
10 x 3	15	6	35	20	516-010-570	516-010-670	15	17	516-010-150
12 x 3	20	7	42	24	516-012-570	516-012-670	18	19	516-012-150
14 x 3	24	10	52	30	516-014-570	516-014-670	21	22	516-014-150
16 x 4	24	10	52	30	516-016-570	516-016-670	24	27	516-016-150
18 x 4	26	11	62	38	516-018-570	516-018-670	27	27	516-018-150
20 x 4	26	11	62	38	516-020-570	516-020-670	30	30	516-020-150
22 x 5	33	13	77	50	516-022-570	516-022-670	33	32	516-022-150
24 x 5	33	13	77	50	516-024-570	516-024-670	36	36	516-024-150
26 x 5	33	13	77	50	516-026-570	516-026-670	42	41	516-026-150
28 x 5	48	15	90	58	516-028-570	516-028-670	42	41	516-028-150
30 x 6	48	15	90	58	516-030-570	516-030-670	45	46	516-030-150
32 x 6	60	20	115	80	516-032-570	516-032-670	48	46	516-032-150
36 x 6	60	20	115	80	516-036-570	516-036-670	54	55	516-036-150
40 x 7	65	20	140	80	516-040-570	516-040-670	60	65	516-040-150
44 x 7	65	20	140	80	516-044-570	516-044-670	66	65	516-044-150
48 x 8	70	20	170	90	516-048-570	516-048-670	72	75	516-048-150
50 x 8	70	20	170	90	516-050-570	516-050-670	75	75	516-050-150
60 x 9							90	90	516-060-150

Kugelgewindetriebe

Ball Screws and Nuts

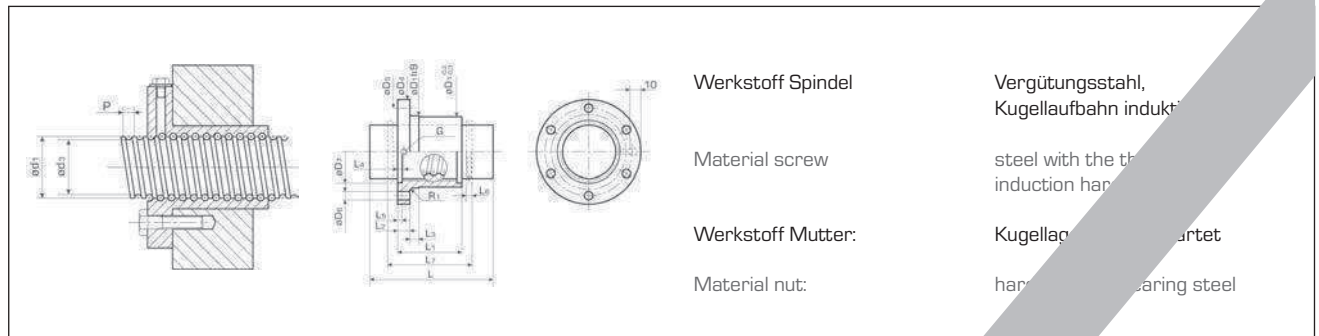

Werkstoff Spindel

Vergütungsstahl,
Kugellaufbahn indukt

Material screw

steel with the th
induction hard

Werkstoff Mutter:

Kugellag

Material nut:

hard

mit Flanschmutter

with flange nut

d ₁	x	p	Tragzahl/load dyn. [kN] stat.		d ₃ ±0,2	U*	L	D ₁	D ₄	D ₅	D ₆	D ₇	L ₁	L ₂	L ₃	L ₄	L ₅	L ₆	L ₇	G	Bestell-Nr. Part No.			
16	x	5	7	12,7	13,4	3	1000	28	48	38	6	22	44	12					7	52	M6	503-165-371		
20	x	5	8	17	17,4	3	1000	32	55	45	7	26	44	12					3	7	52	M6	503-205-371	
25	x	5	9,5	22,4	22,4	3	1000	38	62	50	7	31	46						3	7	54	M6	503-255-371	
32	x	5	17	49	29,4	5	1000	45	70	58	7	38	59						6	3	7	67	M6	503-325-371
40	x	5	19	63,5	37,4	5	1000	53	80	68	7	46							6	3	7	67	M6	503-405-371
40	x	10	30	70	34,7	3	1000	63	95	78	9	52			10	8	5	12	87	87	M8x1	503-401-371		
50	x	10	55	153	44,7	5	1000	72	110	90	11	58			8	10	8	5	12	111	111	M8x1	503-501-371	
63	x	10	60	200	57,7	5	1000	85	125	105	11	66			20	10	8	5	12	113	113	M8x1	503-631-371	
80	x	10	69	260	74,7	5	1000	105	145	125	11	77			21	22	10	8	5	12	115	115	M8x1	503-801-371

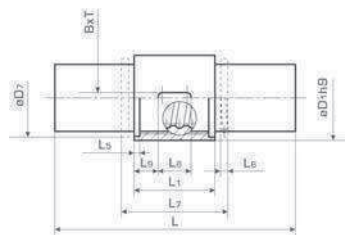

mit Rundmutter

with round nut

d ₁	x	p	Tragzahl/load dyn. [kN] stat.		d ₃ ±0,2		D ₁	D ₇	L ₁	L ₅	L ₆	L ₇	L ₈	L ₉	B	x	T	Bestell-Nr. Part No.	
16	x	5	7	12,7	13,4	3	1000	28	22	34	3	7	42	20	7	5	x	2	503-165-311
20	x	5	8	17	17,4	3	1000	32	26	34	3	7	42	20	7	5	x	2	503-205-311
25	x	5	9,5	22,4	22,4	3	1000	38	31	34	3	7	42	20	7	5	x	2	503-255-311
32	x	5	17	49	29,4	5	1000	45	38	45	3	7	53	30	7	6	x	2,5	503-325-311
40	x	5	19	63,5	37,4	5	1000	53	46	45	3	7	53	30	7	6	x	2,5	503-405-311
40	x	10	30	70	34,7	3	1000	63	52	60	5	12	74	30	15	6	x	2,5	503-401-311
50	x	10	55	153	44,7	5	1000	72	62	82	5	12	96	36	23	6	x	2,5	503-501-311
63	x	10	60	200	57,7	5	1000	85	74	82	5	12	96	36	23	6	x	2,5	503-631-311
80	x	10	69	260	74,7	5	1000	105	93	82	5	12	96	36	23	8	x	3,1	503-801-311

Die WMH Kugelgewindetriebe bestehen aus einer rechtsgängigen, gehärteten und polierten Gewindespindel mit weichgeglühten und polierten Spindelenden zum Weiterbearbeiten sowie aus einer Kugelgewindemutter.

Die Führungsgenauigkeit der Spindel beträgt 0,2/ 300 mm.

Die Kugeln werden in einem internen Umlenkelement von Gang zu Gang zurückgeführt.

Öl- und fettgedichtete Abstreifer sind in die Mutter eingeklebt.

Bei der Demontage bzw. Montage dürfen auf keinen Fall Kugeln herausfallen. Dies führt zu einer Beschädigung der Spindel-Mutter-Einheit. (Montagehülse verwenden!)

Unsere Kugelgewindespindeln können auch in Sonderlängen (bis 5 600 mm) sowie mit fertig bearbeiteten Spindelenden nach Kundenwunsch gegen Aufpreis geliefert werden.

Für besondere Einbaufälle können spielfrei vorgespannte Einheiten (Kugelgewindespindel/ Flanschmutter - Vorspannscheibe - Rund-Kugelgewindemutter) geliefert werden.

The WMH ball screws and nut assemblies consist of a right handed, rolled, induction hardened and polished screw with fully annealed screw ends for subsequent machining and a nut.

The standard tolerance for the accumulated lead error is 0,2 mm over a 300 mm length.

The balls are recirculated in an internal return element from thread to thread.

For effective oil and grease sealing wipers are fitted in the nut and during assembly or removal of the nut care must be taken to prevent the balls

dropping out as this could damage the screw and nut.

Our ball screw and nut assemblies can be delivered in special lengths (up to 5 600 mm) and with suitable for machining screw ends.

For special application free from backlash preloaded units

(ball screw/ flange nut - preload discround nut) can be supplied.

Bearbeitung von Trapezgewindespindeln - Empfehlungen

Lead Screw Machining - Recommendations

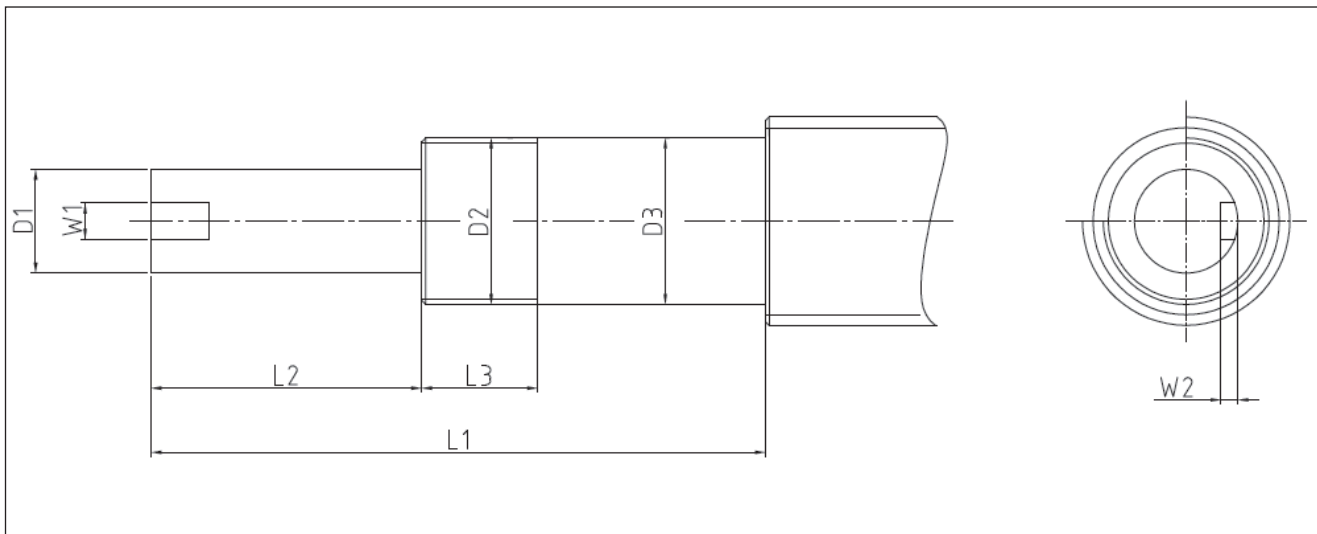

Für Festlager (Flansch- oder Stehlager)

for fixed flanged or pedestal bearings

Bestell-Nr. Part No.	D ₁ (h6)	D ₂	D ₃ (g6)	L ₁	L ₂	L ₃	W ₁	W ₂
502-010-005 502-010-007	8,0	M10x1,0	10,0	54,0	15,0	12,0	2,0	1,2
502-012-005 502-012-007	10,0	M12x1,0	12,0	54,0	15,0	12,0	3,0	1,8
502-015-005 502-015-007	12,0	M15x1,0	15,0	61,0	20,0	12,0	4,0	2,5
502-017-005 502-017-007	15,0	M17x1,0	17,0	80,0	27,0	14,0	5,0	3,0
502-020-005 502-020-007	16,0	M20x1,0	20,0	80,0	27,0	14,0	5,0	3,0
502-025-005 502-025-007	20,0	M25x1,5	25,0	101,0	36,0	18,0	6,0	3,5
502-030-005 502-030-007	25,0	M30x1,5	30,0	114,0	42,0	24,0	8,0	4,0
502-040-005 502-040-007	32,0	M40x1,5	40,0	168,0	70,0	35,0	10,0	5,0

Die Bearbeitung der Spindelenden führen wir selbstverständlich auch nach Ihren Zeichnungen und individuellen Wünschen aus.

Naturally, we also machine shaft ends according to your drawings and individual requirements.

Bearbeitung von Trapezgewindespindeln - Empfehlungen

Lead Screw Machining - Recommendations

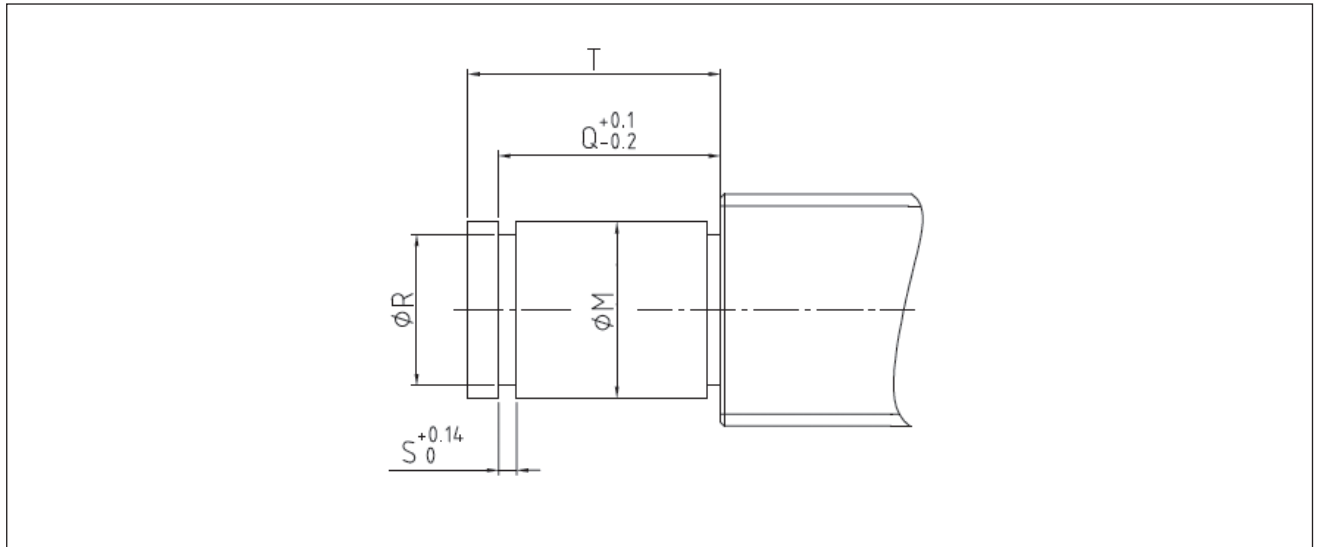

Für Loslager (Flansch- oder Stehlager)

for simple flanged or pedestal bearings

Bestell-Nr. Part No.	ØM (g6)	Q	ØR	S	T
502-008-004 502-008-006	8,0	7,90	7,6	0,90	11,0
502-010-004 502-010-006	10,0	9,15	9,6	1,15	12,0
502-015-004 502-015-006	15,0	10,15	14,3	1,15	12,0
502-017-004 502-017-006	17,0	13,15	16,2	1,15	16,0
502-020-004 502-020-006	20,0	13,35 15,36	19,0	1,35	16,0 18,0
502-025-004 502-025-006	25,0	16,35	23,9	1,35	20,0
502-030-004 502-030-006	30,0	17,75	28,6	1,75	20,0
502-040-004 502-040-006	40,0	19,75	38,0	1,75	25,0

Die Bearbeitung der Spindelenden führen wir selbstverständlich auch nach Ihren Zeichnungen und individuellen Wünschen aus.

Naturally, we also machine shaft ends according to your drawings and individual requirements.

Trapezgewindespindel - Festlager für den Präzisionsbereich

Fixed Lead Screw Support Units - precision range

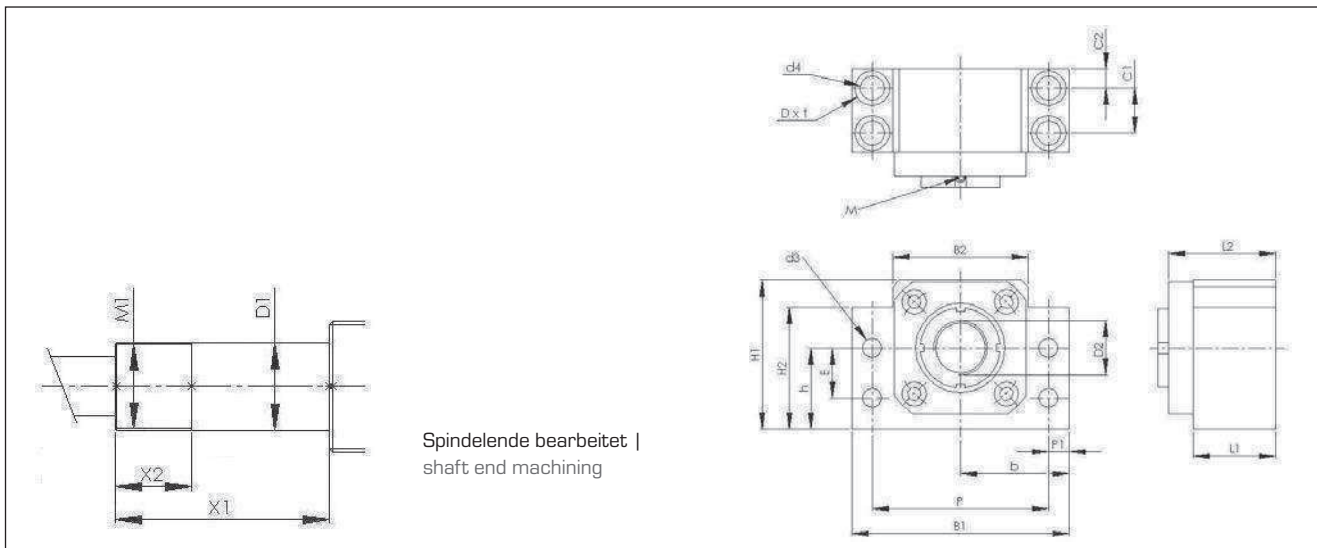

Stehlager

pedestal type

Wellen-Ø D ₁ shaft-Ø D ₁	L ₁	L ₂	M	C ₁	C ₂	H ₁	H ₂	h ±0,02	E	B ₁	B ₂	P	P ₁	b ±0,02	Bestell-Nr. Part No.
10	25	31	M3	13	6	39	32,5	22	15	60	34	46	7	30	502-010-005
12	25	31	M3	13	6	43	35	25	18	60	35	46	7	30	502-012-005
15	27	33	M3	15	6	48	38	28	18	70	40	54	8	35	502-015-005
17	35	43	M4	19	8	64	55	39	28	86	50	68	9	43	502-017-005
20	35	43	M4	19	8	60	50	34	22	88	52	70	9	44	502-020-005
25	42	54	M5	22	10	80	70	48	33	106	64	85	10,5	53	502-025-005
30	45	59	M6	23	11	89	78	51	33	128	76	102	13	64	502-030-005
35	50	64	M8	26	12	96	79	52	35	140	88	114	13	70	502-035-005
40	61	79	M10	33	14	110	90	60	37	160	100	130	15	80	502-040-005

Wellen-Ø D ₁ shaft-Ø D ₁	d ₃	d ₄	D	t	D ₂	X ₁	X ₂	M ₁	verbautes Doppellager bearing set used	Bestell-Nr. Part No.
10	5,5	6,6	11	5	10	39	12	M10x1,0	7000ADFC8P5	502-010-005
12	5,5	6,6	11	6,5	12	39	12	M12x1,0	7001ADFC8P5	502-012-005
15	5,5	6,6	11	6,5	15	41	12	M15x1,0	7002ADFC8P5	502-015-005
17	6,6	9	14	8,5	17	53	14	M17x1,0	7203ADFC8P5	502-017-005
20	6,6	9	14	8,5	20	53	14	M20x1,0	7004ADFC8P5	502-020-005
25	9	11	17,5	11	25	65	18	M25x1,5	7205ADFC8P5	502-025-005
30	11	14	20	13	30	72	24	M30x1,5	7206ADFC8P5	502-030-005
35	11	14	20	13	35	83	28	M35x1,5	7207ADFC8P5	502-035-005
40	14	18	26	17,5	40	98	35	M40x1,5	7208ADFC8P5	502-040-005

Mit paarweise verbauten Schrägkugellagern für eine Montage am Spindelende.

With paired precision a/c bearings for drive end mounting.

Besteht aus Lagergehäuse, Doppellager, Abdeckung, Abstandshalter, Dichtung, Sicherungsmutter und Feststellschraube.

Contains bearing housing, bearing set, cover, spacer, seal, locknut and setscrew.

Trapezgewindespindel - Loslager für den Präzisionsbereich

Simple Lead Screw Support Units - precision range

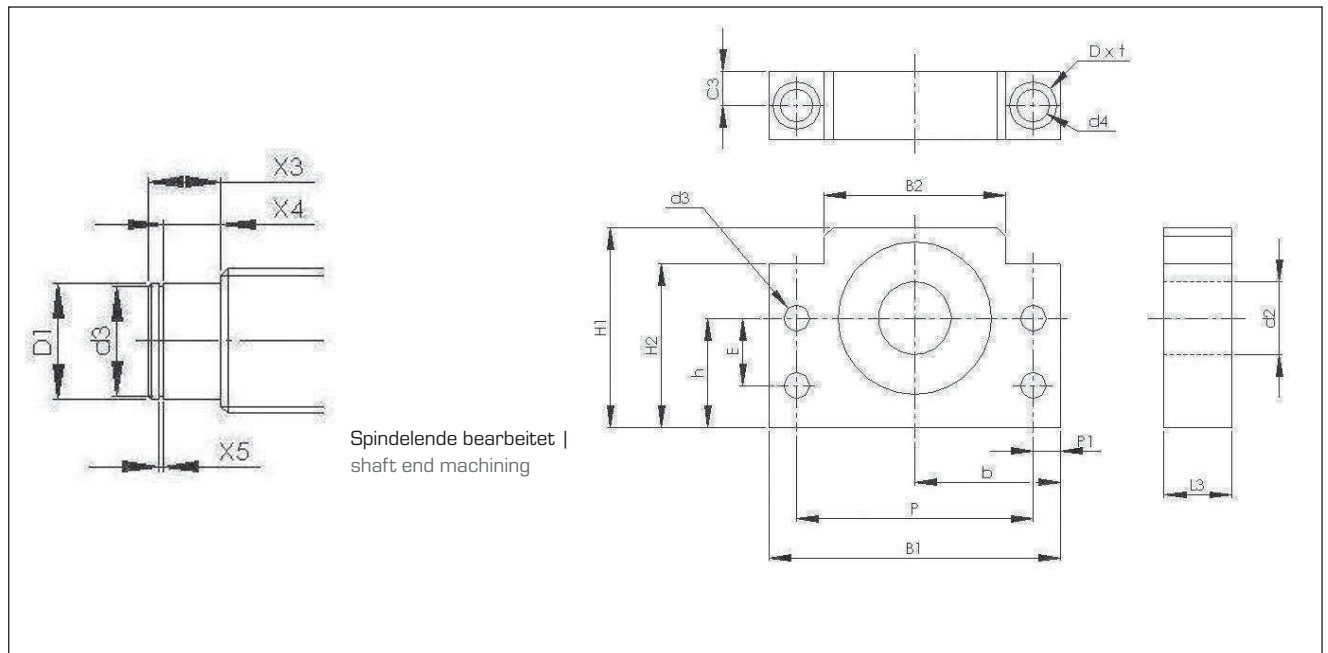

Stahllager

pedestal type

Wellen-Ø D ₁ shaft-Ø D ₁	H ₁	H ₂	h ±0,02	E	B ₁	B ₂	P	P ₁	b ±0,02	Bestell-Nr. Part No.
8	39	32,5	22	15	60	34	46	7	30	502-008-004
10	43	35	25	18	60	35	46	7	30	502-010-004
15	48	38	28	18	70	40	54	8	35	502-015-004
17	64	55	39	28	86	50	68	9	43	502-017-004
20	60	50	34	22	88	52	70	9	44	502-020-004
25	80	70	48	33	106	64	85	10,5	53	502-025-004
30	89	78	51	33	128	76	102	13	64	502-030-004
35	96	79	52	35	140	88	114	13	70	502-035-004
40	110	90	60	37	160	100	130	15	80	502-040-004

Wellen-Ø D ₁ shaft-Ø D ₁	L ₃	d ₂	d ₃	X ₃	X ₄	X ₅	C ₃	d ₄	D	t	verbautes Lager bearing used	Bestell-Nr. Part No.
8	20	8	7,6	11	7,9	0,9	10	6,6	11	5	608ZZ	502-008-004
10	20	10	9,6	12	9,15	1,15	10	6,6	11	6,5	6000ZZ	502-010-004
15	20	15	14,3	12	10,15	1,15	10	6,6	11	6,5	6002ZZ	502-015-004
17	23	17	16,2	16	13,15	1,15	11,5	9	14	8,5	6203ZZ	502-017-004
20	26	20	19	16	13,35	1,35	13	9	14	8,5	6004ZZ	502-020-004
25	30	25	23,9	20	16,35	1,35	15	11	17,5	11	6205ZZ	502-025-004
30	32	30	28,6	20	17,75	1,75	16	14	20	13	6206ZZ	502-030-004
35	32	35	33	25	18,75	1,75	16	14	20	13	6207ZZ	502-035-004
40	37	40	38	25	19,75	1,75	18,5	18	26	17,5	6208ZZ	502-040-004

 Mit einreihigem Rillenkugellager
 zur Montage als Loslager.

 With single row radial bearing for
 non drive end mounting.

Besteht aus Lagergehäuse, Lager und Dichtring.

Contains bearing housing, bearing and circlip.

Trapezgewindespindel - Loslager [Flansch-Ausführung] für den Präzisionsbereich [Flanged] Simple Lead Screw Support Units precision range

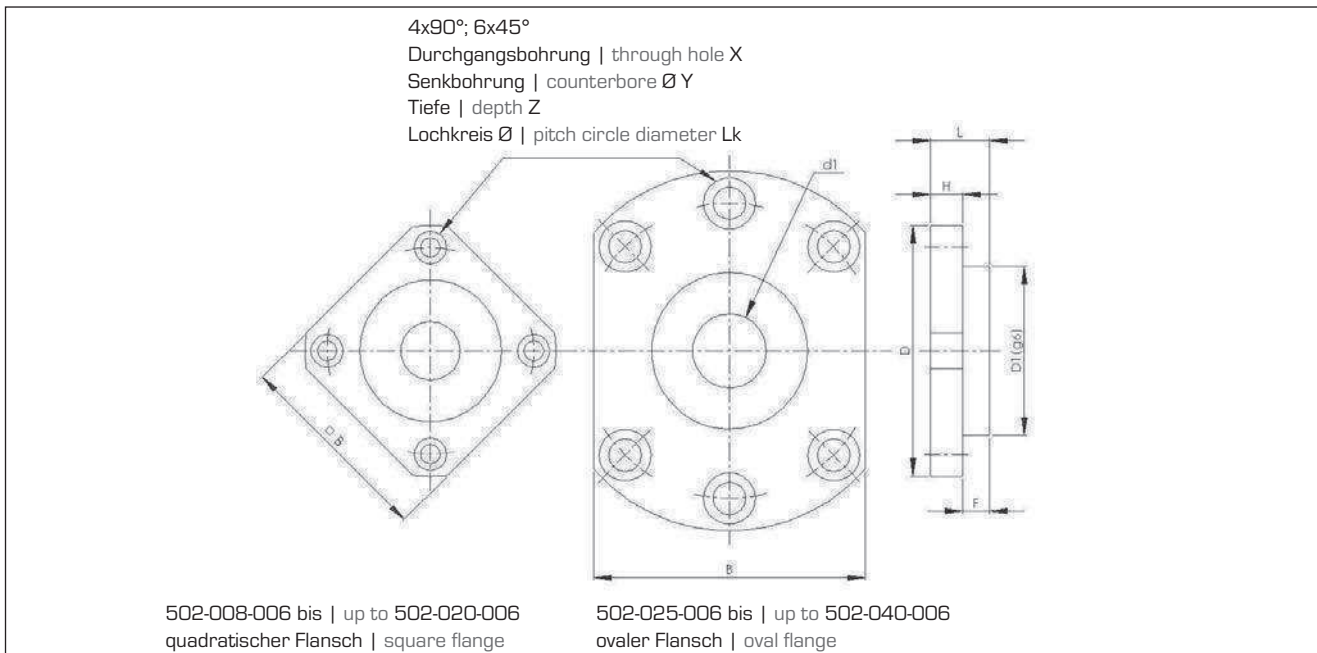

Flanschlager

flange type

Wellen-Ø D ₁ shaft-Ø D ₁	B	Ø Lk ₁	Anz. Bohr. holes	X	Y	Z	D	D ₁ (g6)	L	F	H	Bestell-Nr. Part No.
8	35	35	4	3,4	6,5	4	43	28	12	5	7	502-008-006
10	42	42	4	4,5	8	4	52	34	15	8	7	502-010-006
15	52	50	4	5,5	9,5	6	63	40	17	8	9	502-015-006
17	61	62	4	6,6	11	6,5	77	50	20	9	11	502-017-006
20	68	70	4	6,6	11	6,5	85	57	20	9	11	502-020-006
25	92	100	6	11	17,5	11	122	80	30	15	15	502-025-006
30	106	116	6	11	17,5	11	138	90	32	17	15	502-030-006
40	128	150	8	14	20	13	176	120	36	18	18	502-040-006

Wellen-Ø D ₁ shaft-Ø D ₁	verbautes Lager bearing used	Bestell-Nr. Part No.
8	608ZZ	502-008-006
10	6000ZZ	502-010-006
15	6002ZZ	502-015-006
17	6203ZZ	502-017-006
20	6004ZZ	502-020-006
25	6205ZZ	502-025-006
30	6206ZZ	502-030-006
40	6208ZZ	502-040-006

Mit einreihigem Rillenkugellager zur Montage als Loslager.

With single row radial bearing for non drive end mounting.

Besteht aus Lagergehäuse, Lager und Dichtring.

Contains bearing housing, bearing and circlip.

Trapezgewindespindel - Festlager [Flansch-Ausführung] für den Präzisionsbereich [Flanged] Fixed Lead Screw Support Units - precision range

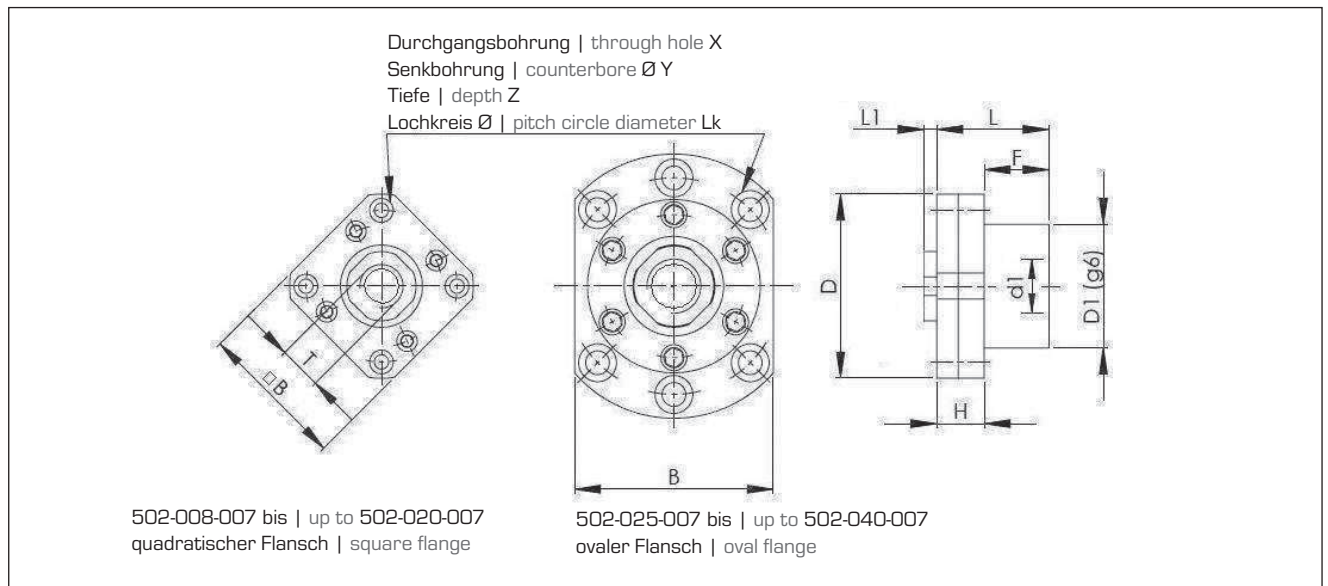

Flanschlager

flange type

Wellen-Ø D_1 shaft-Ø D_1	B	T	Ø Lk	Anz. Bohr- holes	X	Y	Z	D	D_1	L	L_1	F	H	Bestell-Nr. Part No.
10	42	M10x1	42	4	4,5	8	5	52	34	28	8	17	11	502-010-007
12	44	M12x1	44	4	4,5	8	5	54	36	28	8	17	11	502-012-007
15	52	M15x1	50	4	5,5	9,5	6	63	40	32	8	17	15	502-015-007
17	61	M17x1	62	4	6,6	11	10	77	50	45	10	23	22	502-017-007
20	68	M20x1	70	4	6,6	11	10	85	57	52	10	30	22	502-020-007
25	92	M25x1,5	100	6	11	17,5	11	122	80	54	12	27	27	502-025-007
30	106	M30x1,5	116	6	11	17,5	11	138	90	59	12	30	29	502-030-007
40	128	M40x1,5	150	8	14	20	13	176	120	79	19	43	36	502-040-007

Wellen-Ø D_1 shaft-Ø D_1	verbautes Doppellager bearing set used	Bestell-Nr. Part No.
10	7000ADFC8P5	502-010-007
12	7001ADFC8P5	502-012-007
15	7002ADFC8P5	502-015-007
17	7203ADFC8P5	502-017-007
20	7004ADFC8P5	502-020-007
25	7205ADFC8P5	502-025-007
30	7206ADFC8P5	502-030-007
40	7208ADFC8P5	502-040-007

 Mit paarweise verbauten Schrägkugellagern
 für eine Montage am Spindelende.

 With paired precision a/c bearings for
 drive end mounting.

 Besteht aus Lagergehäuse, Doppellager, Abdeckung, Abstands-
 halter, Dichtung, Sicherungsmutter und Feststellschraube.

 Contains bearing housing, bearing set, cover
 spacer, seal, locknut and setscrew.

Technische Information

Technical information

Lagerung support type	Bauart design	Bestell-Nr. Part No.	Tragzahl [kgf]		Radiale Last [kgf]	Maximale axiale
			dynamisch C	statisch Co	dynamisch	Nenn-Last [kgf]
			axial load rating [kgf]		radial load [kgf]	max. usable axial
			dynamic C	static Co	dynamic	load [kgf]
Loslager simple	Fuß pedestal	502-008-004			335	
Loslager simple	Flansch flange	502-008-006			335	
Festlager fixed	Fuß pedestal	502-010-005	620	640		314
Festlager fixed	Flansch flange	502-010-007	620	640		314
Loslager simple	Fuß pedestal	502-010-004			465	
Loslager simple	Flansch flange	502-010-006			465	
Festlager fixed	Fuß pedestal	502-012-005	680	760		331
Festlager fixed	Flansch flange	502-012-007	680	760		331
Loslager simple	Fuß pedestal	502-015-004			570	
Loslager simple	Flansch flange	502-015-006			570	
Festlager fixed	Fuß pedestal	502-015-005	775	970		407
Festlager fixed	Flansch flange	502-015-007	775	970		407
Loslager simple	Fuß pedestal	502-017-004			975	
Loslager simple	Flansch flange	502-017-006			975	
Festlager fixed	Fuß pedestal	502-017-005	1400	1670		595
Festlager fixed	Flansch flange	502-017-007	1400	1670		595
Loslager simple	Fuß pedestal	502-020-004			955	
Loslager simple	Flansch flange	502-020-006			1300	
Festlager fixed	Fuß pedestal	502-020-005	1300	1730		770
Festlager fixed	Flansch flange	502-020-007	1830	2360		970
Loslager simple	Fuß pedestal	502-025-004			1430	
Loslager simple	Flansch flange	502-025-006			1430	
Festlager fixed	Fuß pedestal	502-025-005	2060	2940		1170
Festlager fixed	Flansch flange	502-025-007	2060	2940		1170
Loslager simple	Fuß pedestal	502-030-004			1980	
Loslager simple	Flansch flange	502-030-006			1980	
Festlager fixed	Fuß pedestal	502-030-005	2860	4200		1660
Festlager fixed	Flansch flange	502-030-007	2860	4200		1660
Loslager simple	Fuß pedestal	502-040-004			2970	
Loslager simple	Flansch flange	502-040-006			2970	
Festlager fixed	Fuß pedestal	502-040-005	4500	7200		2770
Festlager fixed	Flansch flange	502-040-007	4500	7200		2770

