

Kegelradgetriebe & Aufsteckstirnradgetriebe

Bevel Gear Units & Shaft-Mounted Spur Gear Reducers



Lagerprogramm

Kegelradgetriebe $i=1:1$ $i=2:1$ $i=3:1$	0 1 - 0 5
Umkehrgetriebe $i=1:1$	0 6
Leistungsangaben Kegelradgetriebe	0 7 - 0 8
Bauarten-Übersicht - Kegelradgetriebe	0 9
Abmessungen - Kegelradgetriebe	0 10 - 0 11
Anbauflansche für Kegelradgetriebe	0 12
Aufsteck-Stirnradgetriebe	0 13

Sonderanfertigungen

Auf Anfrage

Stirnrad-, Kegelstirnrad und Kegelradgetriebe

hohe Übertragungsleistungen,
große Laufruhe und Geräuscharmheit

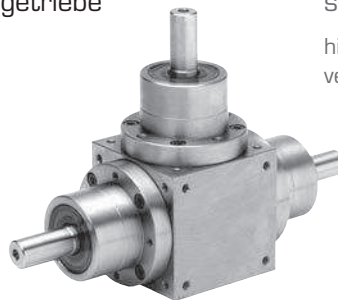

stock programme

Bevel Gear Units ratio 1:1, 2:1, 3:1
Reversible Units ratio 1:1
Performance Data - bevel gear units
Construction Types - bevel gear units
Dimensions - bevel gear units
Assemble Flanges for bevel gear units
Shaft-Mounted Spur Gear Reducers

made to order

on request

spur gear-, bevel spur gear and bevel gear units

high performance and
very silent running



Kegelradgetriebe

Bevel Gear Units

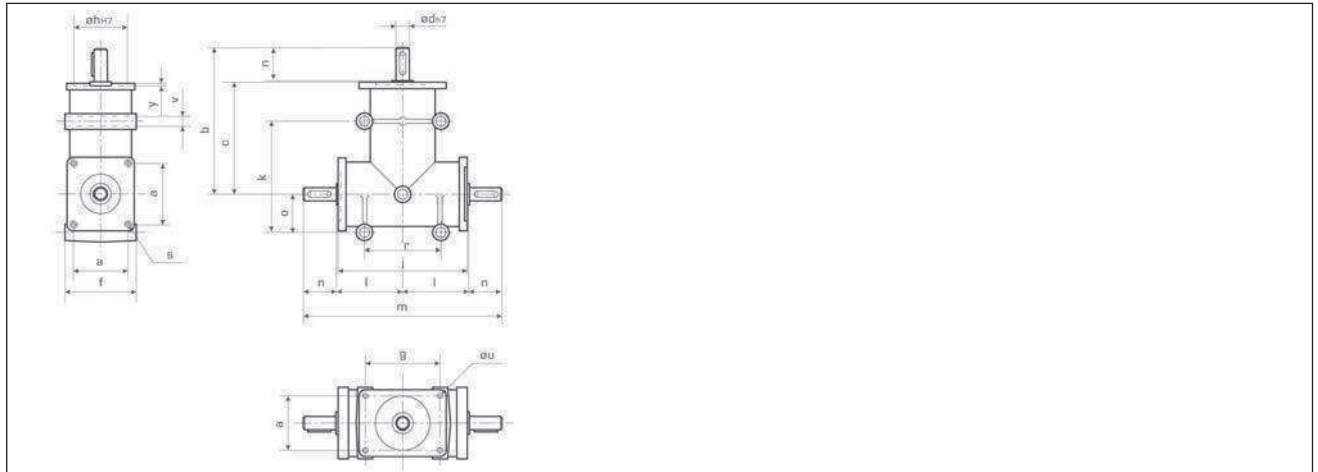

1 Antriebswelle, 2 Abtriebswellen | 1 input shaft, 2 output shafts

		$n_1=1400 \text{ min}^{-1}$																			Bestell-Nr.	
		P_{an}	M_{t2}																		Part No.	
i	[kW]	[Nm]	a	b	c	d	f	g	h	j	k	l	m	n	o	r	s	u	v	y	[kg]	
1:1	0,42	3,0	30	81	60	8*)	43	40	30	75	55	38,5	117	20	20	40	M4	5	5	2,5	0,5	558-002-001
2:1	0,10	1,5	30	81	60	8*)	43	40	30	75	55	38,5	117	20	20	40	M4	5	5	2,5	0,5	558-002-002

1 Antriebswelle, 1 Abtriebswelle/ Wellenanordnung 1 | 1 input shaft, 1 output shaft/ shaft position 1

		$n_1=1400 \text{ min}^{-1}$																			Bestell-Nr.	
		P_{an}	M_{t2}																		Part No.	
i	[kW]	[Nm]	a	b	c	d	f	g	h	j	k	l	m	n	o	r	s	u	v	y	[kg]	
1:1	0,42	3,0	30	81	60	8*)	43	40	30	75	55	38,5		20	20	40	M4	5	5	2,5	0,5	558-000-001
2:1	0,10	1,5	30	81	60	8*)	43	40	30	75	55	38,5		20	20	40	M4	5	5	2,5	0,5	558-000-002

1 Antriebswelle, 1 Abtriebswelle/ Wellenanordnung 2 | 1 input shaft, 1 output shaft/ shaft position 2

		$n_1=1400 \text{ min}^{-1}$																			Bestell-Nr.	
		P_{an}	M_{t2}																		Part No.	
i	[kW]	[Nm]	a	b	c	d	f	g	h	j	k	l	m	n	o	r	s	u	v	y	[kg]	
1:1	0,42	3,0	30	81	60	8*)	43	40	30	75	55	38,5		20	20	40	M4	5	5	2,5	0,5	558-000-101
2:1	0,10	1,5	30	81	60	8*)	43	40	30	75	55	38,5		20	20	40	M4	5	5	2,5	0,5	558-000-102

1 Antriebswelle, 2 Abtriebswellen | 1 input shaft, 2 output shafts

		$n_1=1400 \text{ min}^{-1}$																			Bestell-Nr.	
		P_{an}	M_{t2}																		Part No.	
i	[kW]	[Nm]	a	b	c	d	f	g	h	j	k	l	m	n	o	r	s	u	v	y	[kg]	
1:1	1,83	13,0	46	121	90	14	70	46	47	110	95	56	172	30	32	60	M8	M8	8,5	3	2	558-008-201
2:1	0,50	7,0	46	121	90	14	70	46	47	110	95	56	172	30	32	60	M8	M8	8,5	3	2	558-008-202
3:1	0,25	5,0	46	121	90	14	70	46	47	110	95	56	172	30	32	60	M8	M8	8,5	3	2	558-008-203

Kegelradgetriebe

Bevel Gear Units

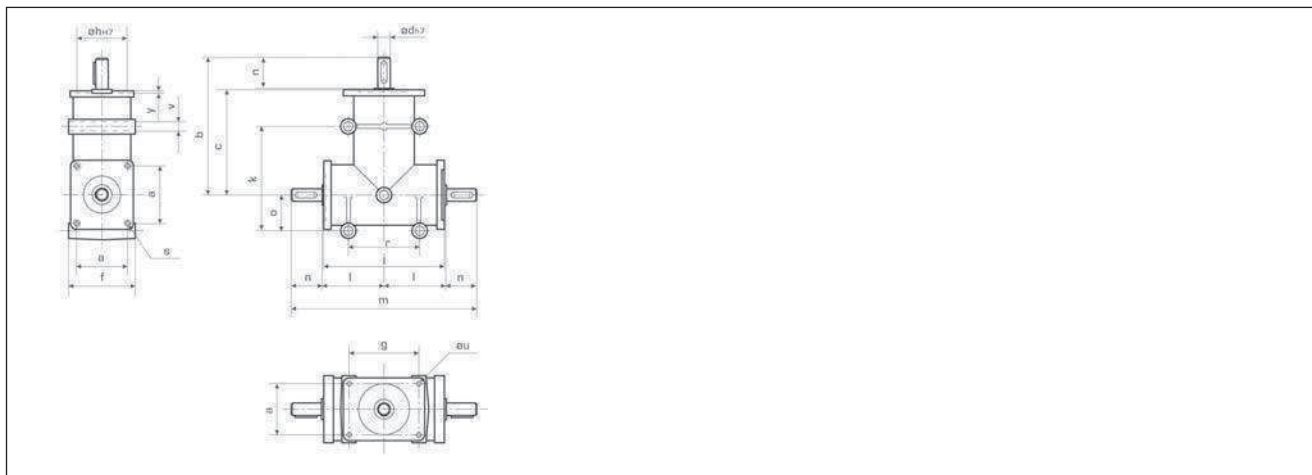

1 Antriebswelle, 1 Abtriebswelle/ Wellenanordnung 1 | 1 input shaft, 1 output shaft/ shaft position 1

$n_1 = 1400 \text{ min}^{-1}$																				Bestell-Nr.	
i	P_{an} [kW]	M_{t2} [Nm]	a	b	c	d	f	g	h	j	k	l	n	o	r	s	u	v	y	[kg]	Part No.
1:1	1,83	13,0	46	121	90	14	70	46	47	110	95	56	30	32	60	M 8	M 8	8,5	3	2	558-011-001
2:1	0,50	7,0	46	121	90	14	70	46	47	110	95	56	30	32	60	M 8	M 8	8,5	3	2	558-011-002
3:1	0,25	5,0	46	121	90	14	70	46	47	110	95	56	30	32	60	M 8	M 8	8,5	3	2	558-011-003

1 Antriebswelle, 1 Abtriebswelle/ Wellenanordnung 2 | 1 input shaft, 1 output shaft/ shaft position 2

$n_1 = 1400 \text{ min}^{-1}$																				Bestell-Nr.	
i	P_{an} [kW]	M_{t2} [Nm]	a	b	c	d	f	g	h	j	k	l	n	o	r	s	u	v	y	[kg]	Part No.
1:1	1,83	13,0	46	121	90	14	70	46	47	110	95	56	30	32	60	M 8	M 8	8,5	3	2	558-011-101
2:1	0,50	7,0	46	121	90	14	70	46	47	110	95	56	30	32	60	M 8	M 8	8,5	3	2	558-011-102
3:1	0,25	5,0	46	121	90	14	70	46	47	110	95	56	30	32	60	M 8	M 8	8,5	3	2	558-011-103

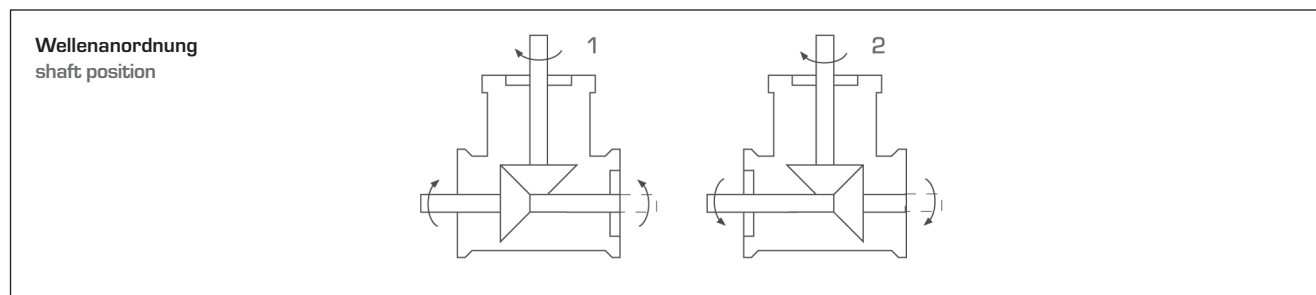

Bei Übersetzungen ins Schnelle $n_{2max} = 1400 \text{ min}^{-1}$
 Kegelräder: Einsatzstahl, spiralverzahnt, einsatzgehärtet und geläppt.
 Gehäuse: Leichtmetall-Legierung
 Öl: 10 - 12° E bei 50 °C
 Keilnuten nach DIN 6885/1

at ratios to speed $n_{2max} = 1400 \text{ r.p.m.}$
 bevel gears: spiral teeth, case hardened steel, lapped.
 case: light metal alloy
 oil: 10 - 12° E at 50 °C
 keyways acc. to DIN 6885/1

*) ohne Nut

*) without keyway

Kegelradgetriebe

Bevel Gear Units

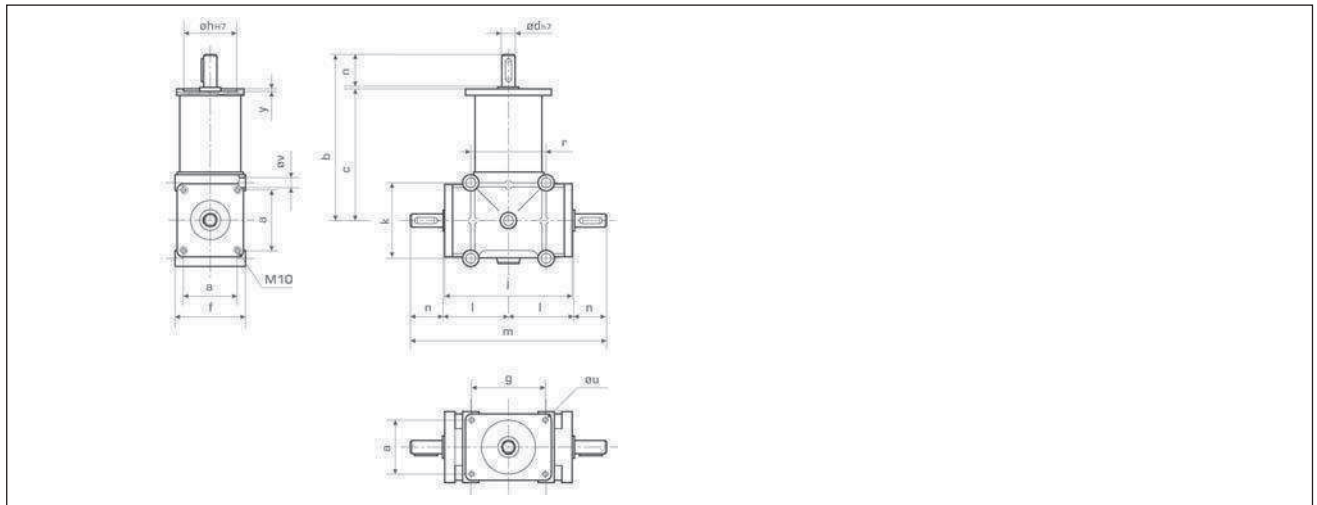

1 Antriebswelle, 2 Abtriebswellen | 1 input shaft, 2 output shafts

i	$n_1=1400 \text{ min}^{-1}$		a	b	c	d	f	g	h	j	k	l	m	n	r	u	v	y	[kg]	Bestell-Nr.
	P_{an} [kW]	M_{t2} [Nm]																		Part No.
1:1	5,50	38,0	60	181	140	19	86	80	62	150	86	76	232	40	86	10,5	10,5	5	4,4	558-031-201
2:1	1,83	25,0	60	181	140	19	86	80	62	150	86	76	232	40	86	10,5	10,5	5	4,4	558-031-202
3:1	0,91	18,0	60	181	140	19	86	80	62	150	86	76	232	40	86	10,5	10,5	5	4,4	558-031-203

1 Antriebswelle, 1 Abtriebswelle/ Wellenanordnung 1 | 1 input shaft, 1 output shaft/ shaft position 1

i	$n_1=1400 \text{ min}^{-1}$		a	b	c	d	f	g	h	j	k	l	m	n	r	u	v	y	[kg]	Bestell-Nr.
	P_{an} [kW]	M_{t2} [Nm]																		Part No.
1:1	5,50	38,0	60	181	140	19	86	80	62	150	86	76		40	86	10,5	10,5	5	4,4	558-030-001
2:1	1,83	25,0	60	181	140	19	86	80	62	150	86	76		40	86	10,5	10,5	5	4,4	558-030-002
3:1	0,91	18,0	60	181	140	19	86	80	62	150	86	76		40	86	10,5	10,5	5	4,4	558-030-003

1 Antriebswelle, 1 Abtriebswelle/ Wellenanordnung 2 | 1 input shaft, 1 output shaft/ shaft position 2

i	$n_1=1400 \text{ min}^{-1}$		a	b	c	d	f	g	h	j	k	l	m	n	r	u	v	y	[kg]	Bestell-Nr.
	P_{an} [kW]	M_{t2} [Nm]																		Part No.
1:1	5,50	38,0	60	181	140	19	86	80	62	150	86	76		40	86	10,5	10,5	5	4,4	558-030-101
2:1	1,83	25,0	60	181	140	19	86	80	62	150	86	76		40	86	10,5	10,5	5	4,4	558-030-102
3:1	0,91	18,0	60	181	140	19	86	80	62	150	86	76		40	86	10,5	10,5	5	4,4	558-030-103

1 Antriebswelle, 1 Abtriebshohlwelle | 1 input shaft, 1 output hollow shaft

i	$n_1=1400 \text{ min}^{-1}$		a	b	c	d	f	g	h	j	k	l	m	n	r	u	v	y	[kg]	Bestell-Nr.
	P_{an} [kW]	M_{t2} [Nm]																		Part No.
1:1	5,50	38,0	60	181	140	19	86	80	62	150	86	76	152		86	10,5	10,5	5	4,8	558-228-201
2:1	1,83	25,0	60	181	140	19	86	80	62	150	86	76	152		86	10,5	10,5	5	4,8	558-228-202
3:1	0,91	18,0	60	181	140	19	86	80	62	150	86	76	152		86	10,5	10,5	5	4,8	558-228-203

Kegelradgetriebe

Bevel Gear Units

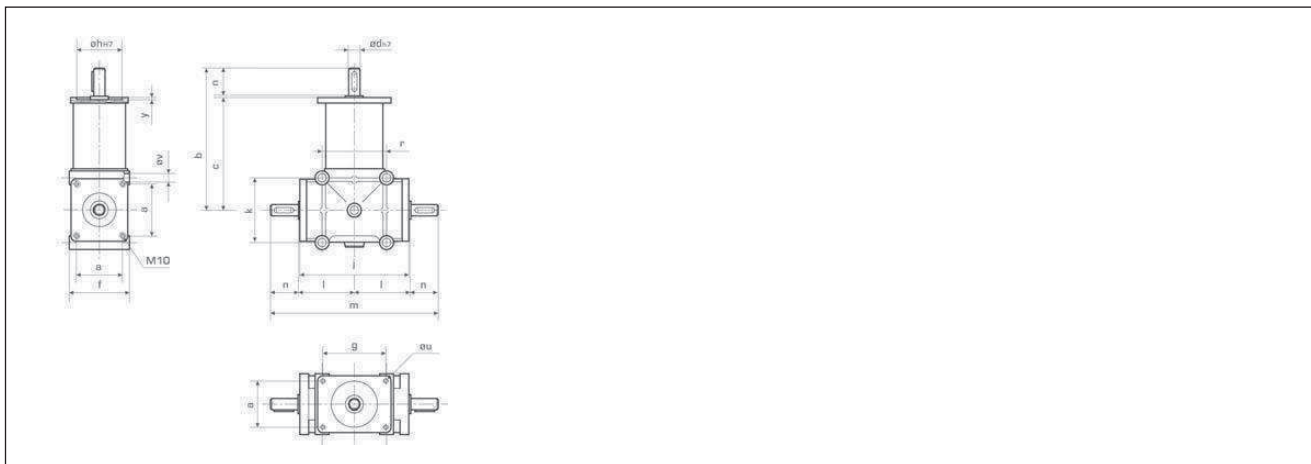

1 Antriebswelle, 2 Abtriebswellen | 1 input shaft, 2 output shafts

i	$n_1 = 1400 \text{ min}^{-1}$																		Bestell-Nr. Part No.	
	P_{an} [kW]	M_{t2} [Nm]	a	b	c	d	f	g	h	j	k	l	m	n	r	u	v	y		[kg]
1:1	7,35	50,0	60	191	140	24	86	80	62	150	86	76	252	50	86	10,5	10,5	5	4,4	558-033-201
2:1	2,94	40,0	60	191	140	24	86	80	62	150	86	76	252	50	86	10,5	10,5	5	4,4	558-033-202
3:1	1,47	28,0	60	191	140	24	86	80	62	150	86	76	252	50	86	10,5	10,5	5	4,4	558-033-203

1 Antriebswelle, 1 Abtriebswelle/ Wellenanordnung 1 | 1 input shaft, 1 output shaft/ shaft position 1

i	$n_1 = 1400 \text{ min}^{-1}$																		Bestell-Nr. Part No.	
	P_{an} [kW]	M_{t2} [Nm]	a	b	c	d	f	g	h	j	k	l	m	n	r	u	v	y		[kg]
1:1	7,35	50,0	60	191	140	24	86	80	62	150	86	76		50	86	10,5	10,5	5	4,4	558-032-001
2:1	2,94	40,0	60	191	140	24	86	80	62	150	86	76		50	86	10,5	10,5	5	4,4	558-032-002
3:1	1,47	28,0	60	191	140	24	86	80	62	150	86	76		50	86	10,5	10,5	5	4,4	558-032-003

1 Antriebswelle, 1 Abtriebswelle/ Wellenanordnung 2 | 1 input shaft, 1 output shaft/ shaft position 2

i	$n_1 = 1400 \text{ min}^{-1}$																		Bestell-Nr. Part No.	
	P_{an} [kW]	M_{t2} [Nm]	a	b	c	d	f	g	h	j	k	l	m	n	r	u	v	y		[kg]
1:1	7,35	50,0	60	191	140	24	86	80	62	150	86	76		50	86	10,5	10,5	5	4,4	558-032-101
2:1	2,94	40,0	60	191	140	24	86	80	62	150	86	76		50	86	10,5	10,5	5	4,4	558-032-102
3:1	1,47	28,0	60	191	140	24	86	80	62	150	86	76		50	86	10,5	10,5	5	4,4	558-032-103

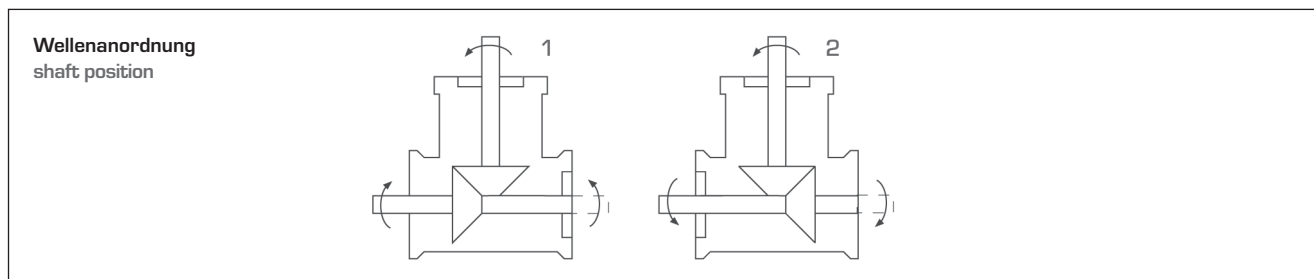

Bei Übersetzungen ins Schnelle $n_{2max} = 1400 \text{ min}^{-1}$
 Kegelräder: Einsatzstahl, spiralverzahnt, einsatzgehärtet und geläppt.
 Gehäuse: Leichtmetall-Legierung
 Öl: 10 - 12° E bei 50 °C
 Keilnuten nach DIN 6885/1

at ratios to speed $n_{2max} = 1400 \text{ r.p.m.}$
 bevel gears: spiral teeth, case hardened steel, lapped.
 case: light metal alloy
 oil: 10 - 12° E at 50 °C
 keyways acc. to DIN 6885/1

Kegelradgetriebe

Bevel Gear Units

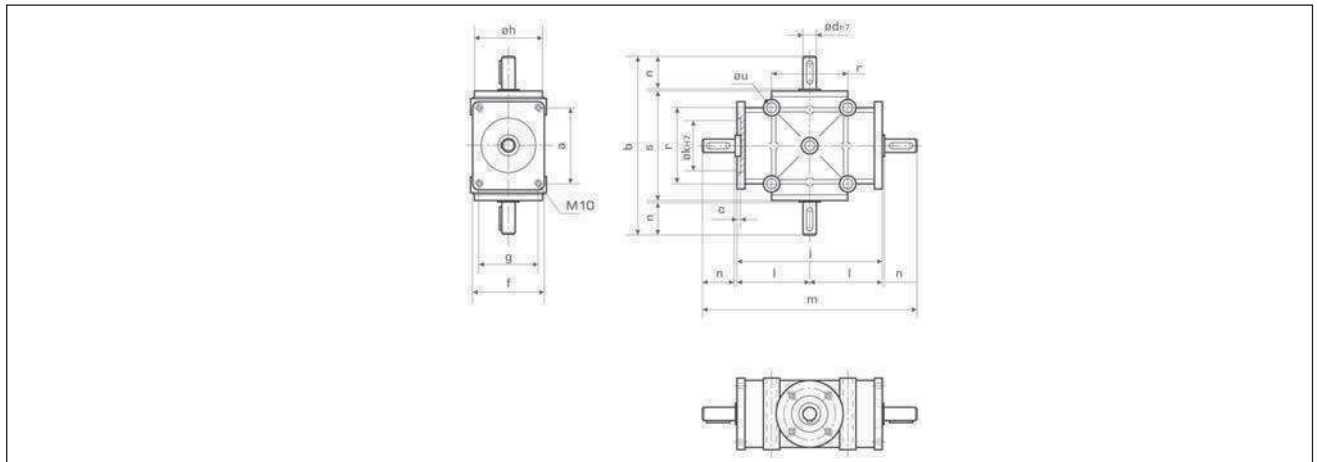

2 Antriebswelle, 2 Abtriebswellen | 2 input shaft, 2 output shafts

i	$n_1=1400 \text{ min}^{-1}$		a	b	c	d	f	g	h	j	k	l	m	n	r	u	v	[kg]	Bestell-Nr.
	P_{an} [kW]	M_{t2} [Nm]																	Part No.
1:1	7,35	54,0	80	231	3	24	86	60	84	182	62	92	284	50	86	131	11	5,35	558-026-201
2:1	2,94	42,0	80	231	3	24	86	60	84	182	62	92	284	50	86	131	11	5,35	558-026-202
3:1	1,47	27,0	80	231	3	24	86	60	84	182	62	92	284	50	86	131	11	5,35	558-026-203

Kegelradgetriebe

Bevel Gear Units

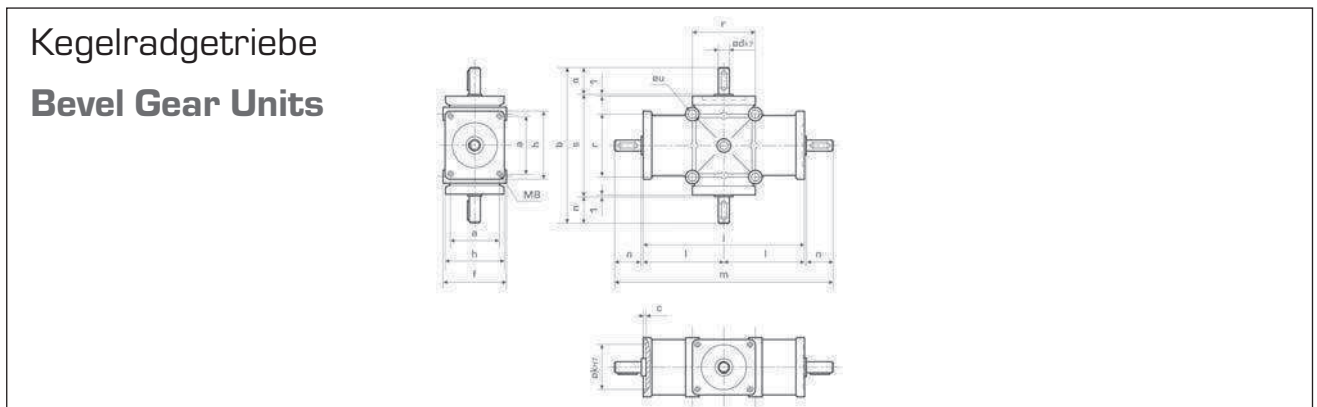

2 Antriebswelle, 2 Abtriebswellen | 2 input shaft, 2 output shafts

i	$n_1=1400 \text{ min}^{-1}$		a	b	c	d	f	g	h	j	k	l	m	n	r	u	v	[kg]	Bestell-Nr.
	P_{an} [kW]	M_{t2} [Nm]																	Part No.
1:1	1,83	13,5	46	172	3	14	70		64	180	47	91	242	30	62	112	8,5	3,25	558-006-201
2:1	0,50	7,5	46	172	3	14	70		64	180	47	91	242	30	62	112	8,5	3,25	558-006-202
3:1	0,25	5,1	46	172	3	14	70		64	180	47	91	242	30	62	112	8,5	3,25	558-006-203

Wellenanordnung
shaft position

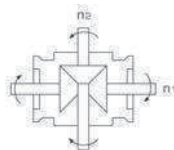

Kegelräder: Einsatzstahl, spiralverzahnt, einsatzgehärtet und geläppt.
 Gehäuse: Leichtmetall-Legierung
 Öl: 10 - 12° E bei 50 °C
 Keilnuten nach DIN 6885/1

bevel gears: spiral teeth, case hardened steel, lapped.
 case: light metal alloy
 oil: 10 - 12° E at 50 °C
 keyways acc. to DIN 6885/1

Kegelradgetriebe

Bevel Gear Units

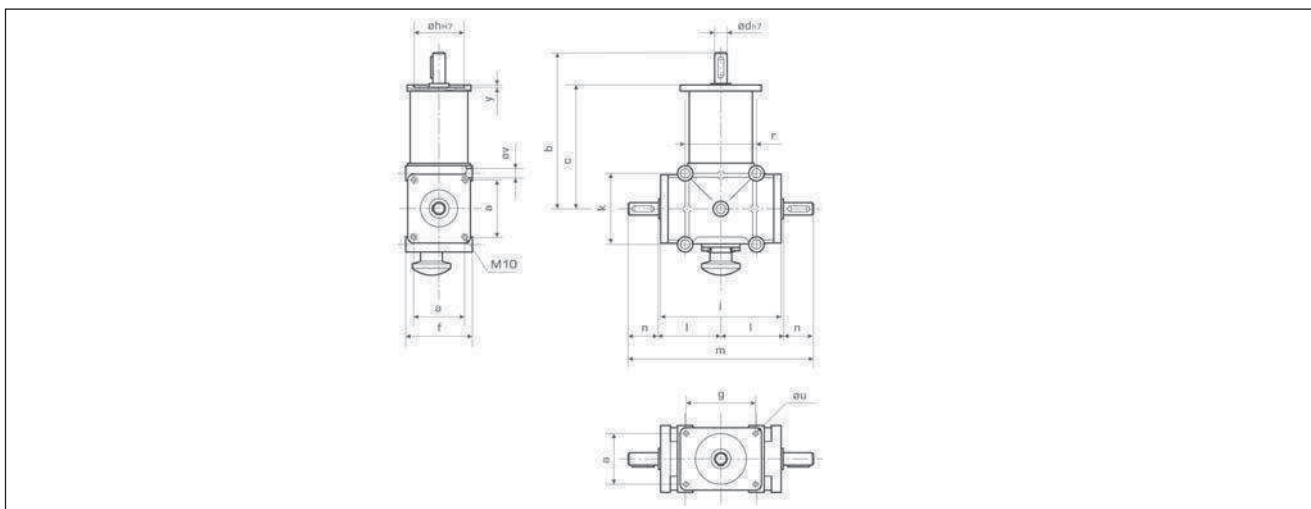

Umkehrgetriebe | reversible unit

$n_1 = 1400 \text{ min}^{-1}$																				Bestell-Nr.
i	P_{an} [kW]	M_{t2} [Nm]	a	b	c	d	f	g	h	j	k	l	m	n	r	u	v	y	[kg]	Part No.
1:1	2,25	15,5	60	181	140	19	86	80	62	150	86	76	232	40	86	10,5	10,5	5	5,5	558-023-201

Wellenanordnung shaft position

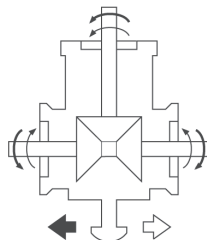

Kegelräder: Einsatzstahl, spiralverzahnt,
einsatzgehärtet und geläppt.
Gehäuse: Leichtmetall-Legierung
Öl: 10 - 12° E bei 50 °C
Keilnuten nach DIN 6885/1

bevel gears: spiral teeth, case hardened
steel, lapped.
case: light metal alloy
oil: 10 - 12° E at 50 °C
keyways acc. to DIN 6885/1

Max. übertragbares Drehmoment je Getriebe | max. transmitting torque per unit
Antriebsleistung | input power

M_{t2} [Nm]
 P_{an} [kW]

Kegelradgetriebe

Bevel Gear Units

[kW] Antriebsleistung | power input
 [Nm] Abtriebsdrehmoment | torque output

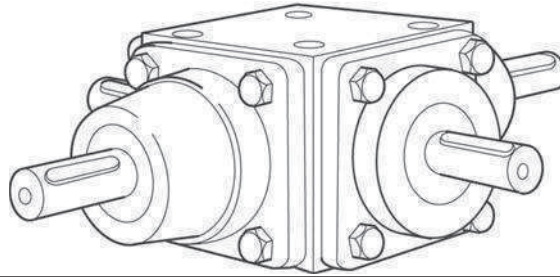

Leistung		output									
Ø Welle Ø shaft [mm]	n ₁ [min ⁻¹]	Übersetzungsverh. i ratio i									
		1 : 1		2 : 1		3 : 1		4 : 1		5 : 1	
		[kW]	[Nm]	[kW]	[Nm]	[kW]	[Nm]	[kW]	[Nm]	[kW]	[Nm]
12	2800	3,08	10,1	1,61	10,6	0,59	5,8				
	2000	2,30	10,6	1,19	10,9	0,46	6,3				
	1500	1,88	11,5	0,94	11,5	0,38	6,9				
	1000	1,36	12,5	0,68	12,5	0,27	7,5				
	800	1,17	13,4	0,59	13,4	0,23	8,1				
	600	0,94	14,4	0,47	14,4	0,19	8,6				
	400	0,67	15,4	0,34	15,4	0,13	8,9				
	100	0,18	16,8	0,09	16,7	0,03	9,4				
	50	0,10	18,2	0,05	18,2	0,02	9,8				
10	0,02	19,2	0,01	19,2	0,01	10,1					
19	2800	16,27	53,3	6,51	42,6	2,40	23,6	2,07	27,1	1,32	21,6
	2000	11,94	54,7	4,73	43,4	1,75	24,0	1,50	27,5	0,96	21,9
	1500	9,17	56,1	3,60	44,0	1,34	24,5	1,13	27,6	0,72	22,1
	1000	6,26	57,4	2,46	45,1	0,91	24,9	0,77	28,3	0,49	22,5
	800	5,07	58,1	1,99	45,7	0,73	25,1	0,62	28,5	0,39	22,6
	600	3,85	58,8	1,51	46,1	0,55	25,4	0,47	28,8	0,30	22,8
	400	2,62	60,0	1,02	46,7	0,37	25,8	0,32	29,0	0,20	22,9
	100	0,69	62,9	0,27	48,8	0,10	26,4	0,08	29,7	0,05	23,4
	50	0,35	63,7	0,13	49,3	0,05	26,6	0,04	29,9	0,03	23,6
10	0,07	64,6	0,03	49,7	0,01	26,8	0,01	30,2	0,01	23,8	
24	2800	17,88	58,6	8,15	53,4	3,52	34,6	3,90	51,1	2,67	43,7
	2000	13,38	61,3	5,99	54,9	2,58	35,4	2,84	52,0	2,01	46,1
	1500	10,37	63,4	4,55	55,7	1,96	36,0	2,16	52,8	1,53	46,8
	1000	7,19	66,0	3,09	56,6	1,33	36,6	1,47	53,8	1,04	47,5
	800	5,86	67,2	2,50	57,2	1,08	37,2	1,18	54,1	0,84	48,0
	600	4,51	68,9	1,89	57,8	0,82	37,4	0,90	54,7	0,65	49,4
	400	3,08	70,6	1,28	58,6	0,55	38,0	0,60	55,3	0,44	49,9
	100	0,82	75,3	0,32	58,9	0,14	38,9	0,15	56,1	0,11	51,4
	50	0,42	77,0	0,16	59,1	0,07	39,0	0,08	57,0	0,06	51,8
10	0,09	79,5	0,03	59,5	0,01	39,2	0,02	57,6	0,01	52,8	
32	2800	40,8	133,4	15,5	101,8	7,33	72,0	5,42	71,0	3,52	57,6
	2000	30,4	139,2	11,5	105,6	5,76	79,2	4,14	75,8	2,64	60,5
	1500	23,6	144,0	8,8	107,5	4,40	80,6	3,14	76,8	2,01	61,4
	1000	16,3	149,8	6,0	109,4	2,98	82,1	2,12	77,8	1,36	62,4
	800	13,3	152,6	4,9	111,4	2,43	83,5	1,72	78,7	1,11	63,4
	600	10,2	156,5	3,7	113,3	1,85	85,0	1,30	79,7	0,85	64,8
	400	7,0	160,3	2,5	115,2	1,26	86,4	0,88	80,6	0,57	65,8
	100	1,9	170,9	0,6	119,0	0,32	89,3	0,23	84,5	0,15	67,2
	50	0,9	174,7	0,3	122,9	0,16	90,7	0,12	86,4	0,07	68,2
10	0,2	180,5	0,1	124,8	0,03	92,2	0,02	88,3	0,02	69,1	

Ø Welle Ø shaft [mm]	n ₁ [min ⁻¹]	Übersetzungsverh. i ratio i									
		1 : 1		2 : 1		3 : 1		4 : 1		5 : 1	
		[kW]	[Nm]	[kW]	[Nm]	[kW]	[Nm]	[kW]	[Nm]	[kW]	[Nm]
38	2800	87,2	285	29,9	196	15,10	148	12,3	161	9,9	162
	2000	64,1	294	22,0	201	11,00	152	9,0	164	7,2	165
	1500	49,4	302	16,9	206	8,40	154	6,8	167	5,5	168
	1000	33,8	310	11,6	212	5,76	158	4,6	170	3,7	171
	800	27,6	316	9,4	215	4,66	160	3,7	171	3,0	173
	600	21,1	323	7,1	218	3,55	162	2,8	173	2,3	175
	400	14,5	331	4,8	222	2,40	165	1,9	176	1,5	176
	100	3,8	349	1,3	231	0,62	170	0,5	182	0,4	182
	50	1,9	355	0,6	234	0,31	172	0,25	183	0,2	184
	10	0,4	367	0,13	239	0,06	175	0,05	186	0,04	186
42	2800	102,6	336	35,2	230	17,8	175	13,7	180	9,9	162
	2000	75,4	346	25,8	237	13,0	178	10,0	183	7,2	166
	1500	58,1	355	19,8	243	9,9	181	7,6	187	5,5	168
	1000	39,8	365	13,6	249	6,8	186	5,2	191	3,7	171
	800	32,5	372	11,0	253	5,5	188	4,2	193	3,0	173
	600	24,9	380	8,4	257	4,2	191	3,2	195	2,3	175
	400	17,0	390	5,7	261	2,8	194	2,2	198	1,5	177
	100	4,5	411	1,5	272	0,7	201	0,6	204	0,4	182
	50	2,3	420	0,75	278	0,37	203	0,25	206	0,2	184
	10	0,5	432	0,15	281	0,07	206	0,05	209	0,04	186
55	1500	125	763	44,4	543	20,2	370	19,5	478	15,0	458
	1000	86	787	30,6	561	13,9	382	13,3	489	10,2	467
	800	70	800	24,8	568	11,3	386	10,8	495	8,2	472
	600	53	810	18,8	576	8,5	391	8,2	501	6,3	478
	400	36	840	12,9	591	5,8	398	5,6	509	4,2	484
	100	10	893	3,4	618	1,5	416	1,4	529	1,1	503
	50	5	912	1,7	632	0,8	421	0,7	534	0,6	508
	10	1	941	0,35	643	0,16	428	0,15	543	0,1	515
75	1500	265	1622	109	1325	74	1363	46	1128	32	983
	1000	185	1694	75	1368	51	1402	32	1158	22	1007
	800	151	1728	61	1391	41	1423	26	1173	18	1018
	600	116	1770	46	1416	32	1447	19	1190	14	1032
	400	80	1824	32	1449	21	1475	13	1212	9	1049
	100	21	1963	8	1532	6	1550	3	1265	2	1091
	50	11	2009	4	1560	3	1574	2	1282	1	1104
	10	2,3	2077	0,9	1597	0,6	1606	0,4	1306	0,2	1121

	Wellenbelastung shaft loads (max.)		Antriebswelle Input shaft		Abtriebswelle output shaft			***	Bestell-Nr. Part No.
	PR 1	PA1	PR2	PA2	PR2	PA2	PA2		
R = Radial	550	300	900	500	y		557-12-20.		
	850	450	1500	700	y		557-19-20.		
A = Axial	600	400	1500	700	z		557-19-20.		
	1400	700	2200	1300	y		557-24-20.		
	850	450	2200	1300	z		557-24-20.		
	2000	1100	3500	1700	y		557-32-20.		
	1400	700	3500	1700	z		557-32-20.		
	4000	1700	7000	3400	y		557-38-20.		
	2000	1100	7000	3400	z		557-38-20.		
	6000	2700	10000	4800	y		557-42-20.		
	4000	1700	10000	4800	z		557-42-20.		
	10000	5000	15000	6800	y		557-55-20.		
	6000	2700	15000	6800	z		557-55-20.		
	25000	10000	35000	15000	y		557-75-20.		
10000	5000	35000	15000	z		557-75-20.			

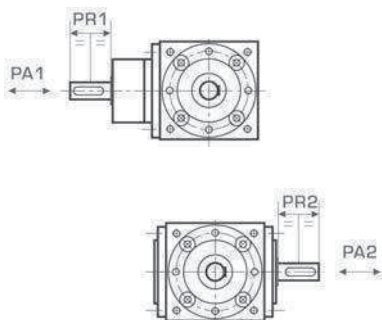

Kegelradgetriebe

Bevel Gear Units

Bestellbeispiel | example:

Best.-Nr. | Part No.: **557-612-202**

557-

Kegelradgetriebe | bevel gear unit

612-

6 Ausführung | construction

12 Ø Welle | Ø shaft * * (12 mm;...75mm)

202

20 Bauart | construction typ

2 Übersetzung | ratio * (1:1;...5:1)

1:1 entspricht | corresponds to no. 1 4:1 entspricht | corresponds to no. 4

2:1 entspricht | corresponds to no. 2 5:1 entspricht | corresponds to no. 5

Übersetzung | ratio * 3:1 entspricht | corresponds to no. 3

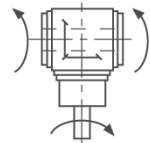
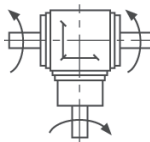
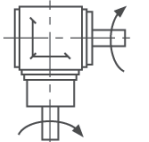
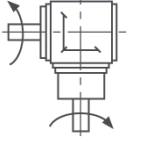
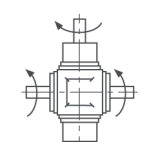
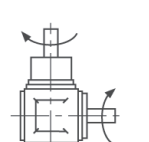
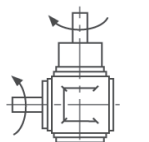
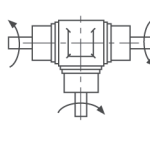
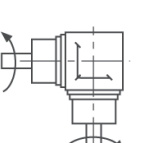
Bauart construction typ	20	11	12
Ausführung construction 5	 langsam laufende Hohlwelle hollow shaft, slow 557-5* *-20*		
Ausführung construction 6	 doppelseitige, langsam laufende Welle slow shaft, double projection 557-6* *-20*	 einseitige, langsam laufende Welle slow shaft, single projection 557-6* *-11*	 einseitige, langsam laufende Welle slow shaft, single projection 557-6* *-12*
Ausführung construction 7	 doppelseitige, langsam laufende Welle; 2. Welle schnell laufend slow shaft, double projection; 2 fast shafts, counter rotating 557-7* *-20*	 einseitige, langsam laufende Welle; zwei schnell laufende Wellen slow shaft, single projection; 2 fast shafts, counter rotating 557-7* *-11*	 einseitige, langsam laufende Welle; zwei schnell laufende Wellen slow shaft, single projection; 2 fast shafts, counter rotating 557-7* *-12*
Ausführung construction 8	 doppelseitige, gegenläufige, langsam laufende Welle double projection, counter rotating slow shaft 557-8* *-20*		 einseitige, verstärkte, langsam laufende Welle slow shaft, single projection with bearing housing 557-8* *-12*

Kegelradgetriebe

Bevel Gear Units

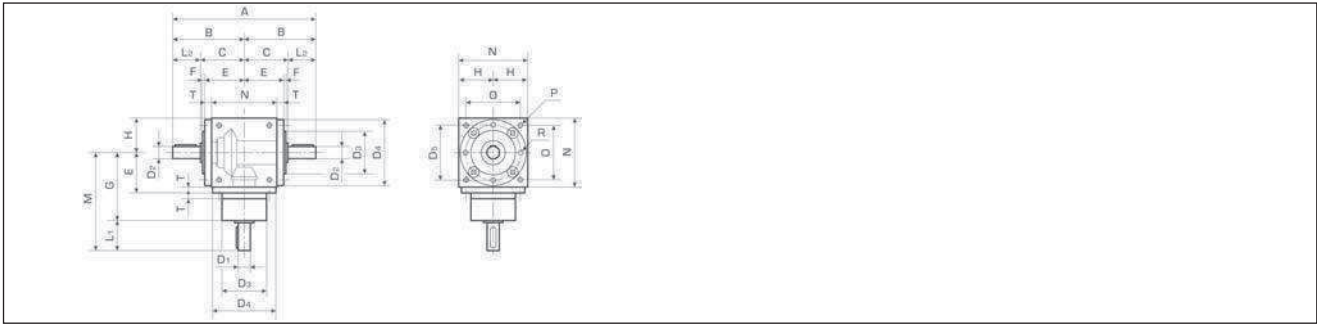

D ₁	D ₂	D ₃	D ₄	D ₅	A	B	C	E	F	G	H	L ₁	L ₂	M	N	O	P/R	T	***	Bestell-Nr. Part No.
12	12	44		54	144	72	46	42	2	74	32,5	26	26	100	65	45	M 6		y	557-612-20.*
19	19	60	86	72	210	105	65	59	4	100	45	40	40	140	90	70	M 6	14	y	557-619-20.*
14	19	60	86	72	210	105	65	59	4	100	45	30	40	130	90	70	M 6	14	z	557-619-20.*
24	24	70	105	88	260	130	80	73	5	115	55	50	50	165	110	88	M 8	18	y	557-624-20.*
19	24	70	105	88	260	130	80	73	5	115	55	40	50	155	110	88	M 8	18	z	557-624-20.*
32	32	95	135	115	310	155	95	88	5	145	70	60	60	205	140	110	M 10	18	y	557-632-20.*
24	32	95	135	115	310	155	95	88	5	145	70	50	60	195	140	110	M 10	18	z	557-632-20.*
38	38	120	165	145	360	180	110	103	5	170	85	70	70	240	170	136	M 12	18	y	557-638-20.*
28	38	120	165	145	360	180	110	103	5	170	85	60	70	230	170	136	M 12	18	z	557-638-20.*
42	42	135	190	165	410	205	125	118	5	195	100	80	80	275	200	155	M 12	18	y	557-642-20.*
32	42	135	190	165	410	205	125	118	5	195	100	60	80	255	200	155	M 12	18	z	557-642-20.*
55	55	170	230	205	520	260	150	143	5	245	120	110	110	355	240	190	M 14	23	y	557-655-20.*
42	55	170	230	205	520	260	150	143	5	245	120	80	110	325	240	190	M 14	23	z	557-655-20.*
75	75		300		750	375	225	195		350	165	150	150	500	330	248	M 16	30	y	557-675-20.*
55	75		300		750	375	225	195		350	165	110	150	460	330	248	M 16	30	z	557-675-20.*

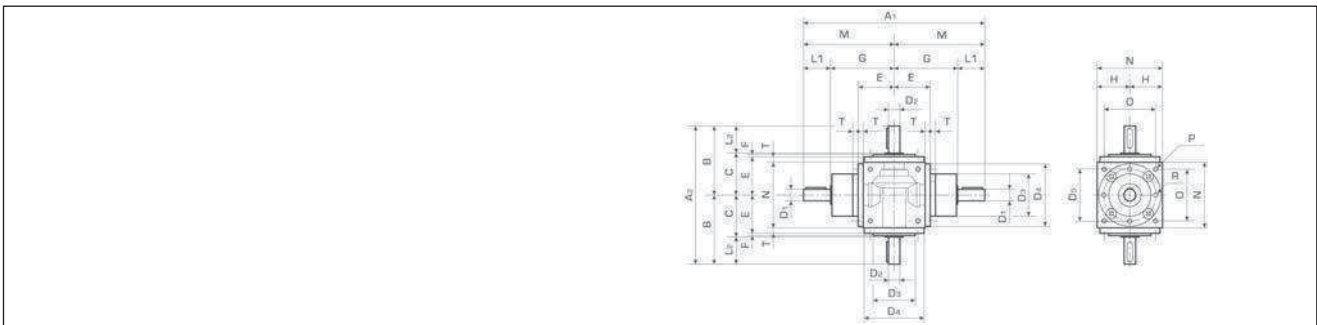

D ₁	D ₂	D ₃	D ₄	D ₅	A ₁	A ₂	B	C	E	F	G	H	L ₁	L ₂	M	N	O	P/R	T	***	Bestell-Nr. Part No.
12	12	44		54	200	144	72	46	42	2	74	32,5	26	26	100	65	45	M 6		y	557-712-20.*
19	19	60	86	72	280	210	105	65	59	4	100	45	40	40	140	90	70	M 6	14	y	557-719-20.*
14	19	60	86	72	260	210	105	65	59	4	100	45	30	40	130	90	70	M 6	14	z	557-719-20.*
24	24	70	105	88	330	260	130	80	73	5	115	55	50	50	165	110	88	M 8	18	y	557-724-20.*
19	24	70	105	88	310	260	130	80	73	5	115	55	40	50	155	110	88	M 8	18	z	557-724-20.*
32	32	95	135	115	410	310	155	95	88	5	145	70	60	60	205	140	110	M 10	18	y	557-732-20.*
24	32	95	135	115	390	310	155	95	88	5	145	70	50	60	195	140	110	M 10	18	z	557-732-20.*
38	38	120	165	145	480	360	180	110	103	5	170	85	70	70	240	170	136	M 12	18	y	557-738-20.*
28	38	120	165	145	460	360	180	110	103	5	170	85	60	70	230	170	136	M 12	18	z	557-738-20.*
42	42	135	190	165	550	410	205	125	118	5	195	100	80	80	275	200	155	M 12	18	y	557-742-20.*
32	42	135	190	165	510	410	205	125	118	5	195	100	60	80	255	200	155	M 12	18	z	557-742-20.*
55	55	170	230	205	710	520	260	150	143	5	245	120	110	110	355	240	190	M 14	23	y	557-755-20.*
42	55	170	230	205	650	520	260	150	143	5	245	120	80	110	325	240	190	M 14	23	z	557-755-20.*
75	75		300		1000	750	375	225	195		350	165	150	150	500	330	248	M 16	30	y	557-775-20.*
55	75		300		920	750	375	225	195		350	165	110	150	460	330	248	M 16	30	z	557-775-20.*

* Übersetzungsverh. i | ratio i

*** y → i: 1:1 / 2:1 / 3:1
z → i: 4:1 / 5:1

Kegelradgetriebe

Bevel Gear Units

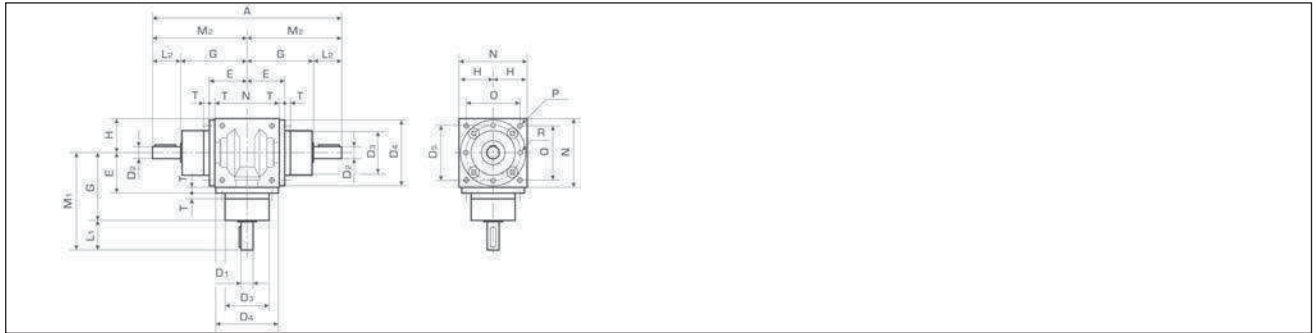

D ₁	D ₂	D ₃	D ₄	D ₅	A	E	G	H	L ₁	L ₂	M ₁	M ₂	N	O	P/R	T	***	Bestell-Nr. Part No.
12	12	44		54	200	42	74	32,5	26	26	100	100	65	45	M 6		y	557-812-20.*
19	19	60	86	72	280	59	100	45	40	40	140	140	90	70	M 6	14	y	557-819-20.*
14	19	60	86	72	280	59	100	45	30	40	130	140	90	70	M 6	14	z	557-819-20.*
24	24	70	105	88	330	73	115	55	50	50	165	165	110	88	M 8	18	y	557-824-20.*
19	24	70	105	88	330	73	115	55	40	50	155	165	110	88	M 8	18	z	557-824-20.*
32	32	95	135	115	410	88	145	70	60	60	205	205	140	110	M 10	18	y	557-832-20.*
24	32	95	135	115	410	88	145	70	50	60	195	205	140	110	M 10	18	z	557-832-20.*
38	38	120	165	145	480	103	170	85	70	70	240	240	170	136	M 12	18	y	557-838-20.*
28	38	120	165	145	480	103	170	85	60	70	230	240	170	136	M 12	18	z	557-838-20.*
42	42	135	190	165	550	118	195	100	80	80	275	275	200	155	M 12	18	y	557-842-20.*
32	42	135	190	165	550	118	195	100	60	80	255	275	200	155	M 12	18	z	557-842-20.*
55	55	170	230	205	710	143	245	120	110	110	355	355	240	190	M 14	23	y	557-855-20.*
42	55	170	230	205	710	143	245	120	80	110	325	355	240	190	M 14	23	z	557-855-20.*
75	75		300		1000	195	350	165	150	150	500	500	330	248	M 16	30	y	557-875-20.*
55	75		300		1000	195	350	165	110	150	460	500	330	248	M 16	30	z	557-875-20.*

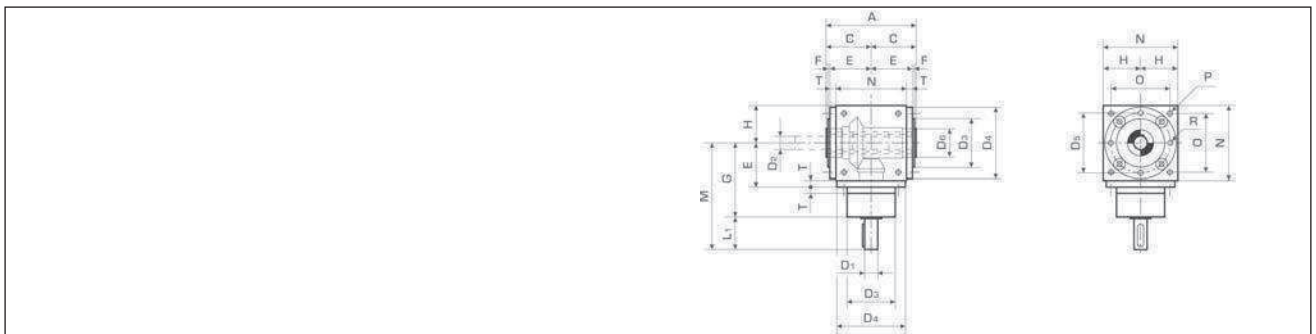

D ₁	D ₂	D ₃	D ₄	D ₅	D ₆	A	C	E	F	G	H	L ₁	M	N	O	P/R	T	***	Bestell-Nr. Part No.
19	19	60	86	72	30	130	65	59	4	100	45	40	140	90	70	M 6	14	y	557-519-20.*
14	19	60	86	72	30	130	65	59	4	100	45	30	130	90	70	M 6	14	z	557-519-20.*
24	24	70	105	88	35	160	80	73	5	115	55	50	165	110	88	M 8	18	y	557-524-20.*
19	24	70	105	88	35	160	80	73	5	115	55	40	155	110	88	M 8	18	z	557-524-20.*
32	32	95	135	115	50	190	95	88	5	145	70	60	205	140	110	M 10	18	y	557-532-20.*
24	32	95	135	115	50	190	95	88	5	145	70	50	195	140	110	M 10	18	z	557-532-20.*
38	38	120	165	145	60	220	110	103	5	170	85	70	240	170	136	M 12	18	y	557-538-20.*
28	38	120	165	145	60	220	110	103	5	170	85	60	230	170	136	M 12	18	z	557-538-20.*
42	42	135	190	165	60	250	125	118	5	195	100	80	275	200	155	M 12	18	y	557-542-20.*
32	42	135	190	165	60	250	125	118	5	195	100	60	255	200	155	M 12	18	z	557-542-20.*
55	55	170	230	205	75	300	150	143	5	245	120	110	355	240	190	M 14	23	y	557-555-20.*
42	55	170	230	205	75	300	150	143	5	245	120	80	325	240	190	M 14	23	z	557-555-20.*
75	75		300		120	450	225	195		350	165	150	500	330	248	M 16	30	y	557-575-20.*
55	75		300		120	450	225	195		350	165	110	460	330	248	M 16	30	z	557-575-20.*

* Übersetzungsverh. i | ratio i

*** y → i: 1:1 / 2:1 / 3:1
z → i: 4:1 / 5:1

Kegelradgetriebe

Bevel Gear Units

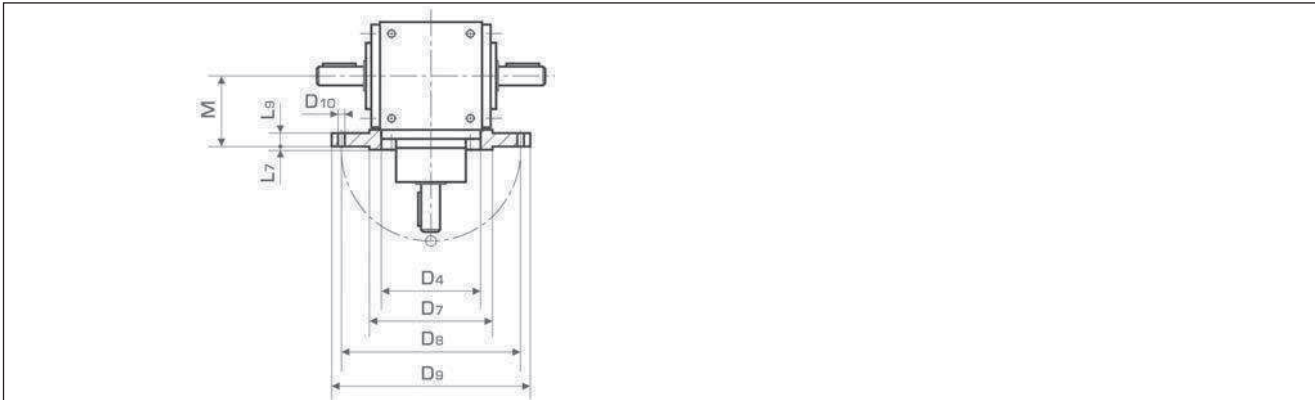

Anbauflansch								assemble flange
D ₉	D ₄	D ₇	D ₈	D ₁₀	L ₇	L ₉	M	Bestell-Nr. Part No.
160	86	110	130	9	3,5	12	70	557-019-160
200	105	130	165	11	3,5	13	85	557-024-200
250	135	180	215	14	4	15	105	557-032-250
300	165	230	265	14	4	15	125	557-038-300
300	190	230	265	14	4	15	145	557-042-300
350	230	250	300	18	5	18	175	557-055-350
450	300	350	400	18	5	25	230	557-075-450

Die würfelförmigen Gehäuse bestehen aus Grauguß. Die bogenverzahnten Kegelräder sind gehärtet und geläppt. Die Kegelradgetriebe werden mit Fließfettfüllung (3/4 voll) geliefert. Das Fließfett ist erstmalig nach 500 Std. sowie nach weiteren je 3 000 Std. Laufzeit zu erneuern.

The cuboid boxes are made from cast iron. The spiral bevel gears are hardened and lapped. The gearboxes are filled with grease (to 3/4 full). Lubricants should be changed after the first 500 running hours and subsequently after every 3 000 running hours.

Aufsteckstirnradgetriebe

Shaft-Mounted Spur Gear Reducers

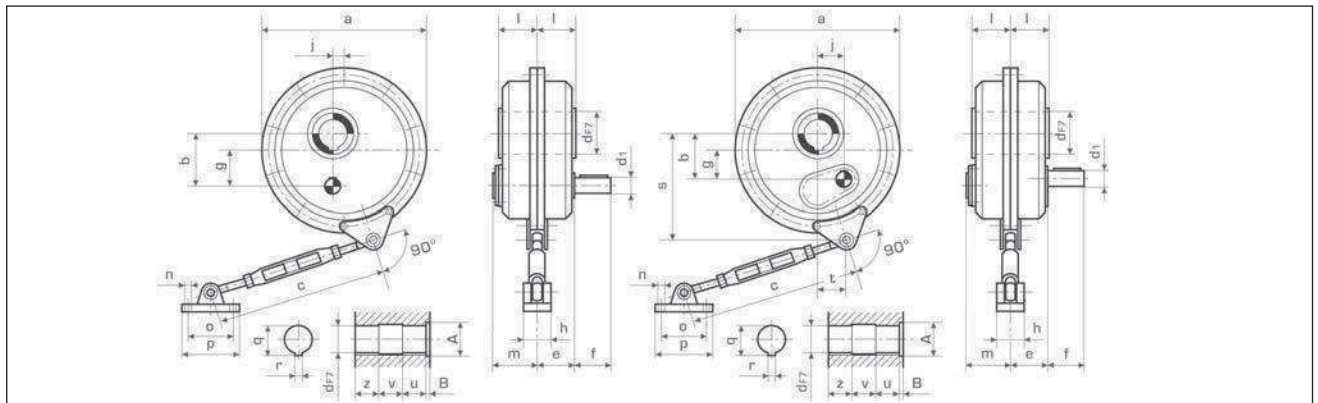

Abmessungen

dimensions

Baugruppe

size	A	B	a	b	c _{min}	c _{max}	d	d ₁	e	f	g	h	j	l	m	n	o	p	q	r	u	v	z	s	t
210	42	12	246	78	420	520	35	19	67	38	55	40	17	64	62	10	60	80	38,3	10	28	28	60	165	38
211	50	15	275	90	320	460	40	24	75	50	65	45	18	70	80	11	75	100	43,3	12	42	53	30	181	32
212	60	18	294	95	320	460	50	28	85	60	65	55	18	80	90	14	90	125	54,4	14	47	45	50	210	47
213	72	20	350	115	320	460	60	32	100	80	78	55	22	92	102	14	90	125	64,4	18	58	68	40	242	60
214	88	22	410	132	400	500	70	38	110	90	90	72	28	100	111	18	115	155	74,9	20	62	71	45	266	74
215	100	25	495	170	400	500	85	42	130	100	120	72	30	115	121	18	115	155	90,4	22	72	83	50	320	72
216	120	25	585	232	500	680	100	50	145	110	152	85	140	143	22	140	190	106,4	28	72	103	80	400	85	
217	140	32	650	260	500	680	120	55	175	110	170	85	165	166	22	140	190	127,4	32	100	98	100	435	93	
218	160	40	780	308	640	830	140	65	185	140	203	110	184	198	30	170	230	148,4	36	110	108	110	542	85	
219	175	40	910	355	640	830	150	75	215	140	237	110	210	222	30	170	230	158,4	36	125	130	125	615	90	
316	120	25	585	207	500	680	100	40	145	80	127	85	96,8	140	143	22	140	190	106,4	28	72	103	80	400	80
317	140	32	650	230	500	680	120	48	175	100	140	85	105,8	165	166	22	140	190	127,4	32	100	98	110	435	80
318	160	40	780	263	640	830	140	55	185	110	158	110	121,9	184	198	30	170	230	148,4	36	110	108	110	542	85
319	175	40	910	305	640	830	150	60	215	120	187	110	130,8	210	222	30	170	230	158,4	36	125	130	125	615	90

Leistung

output

Baugruppe		n ₂ = 10 min ⁻¹		n ₂ = 20 min ⁻¹		n ₂ = 50 min ⁻¹		n ₂ = 80 min ⁻¹		n ₂ = 100 min ⁻¹		Bestell-Nr.	
size	i	[kW]	[Nm]	[kW]	[Nm]	[kW]	[Nm]	[kW]	[Nm]	[kW]	[Nm]	[kg]	Part No.
210	15,5:1	0,48	440	0,97	440	2,4	440	2,8	340	3	270	16	520-210-015
211	14,69:1	0,75	690	1,5	690	3,7	670	5,1	600	6	590	22,5	520-211-015
212	14,28:1	1,2	1080	2,4	1080	5,8	1060	8,6	960	10,1	930	30,5	520-212-015
213	14,8:1	1,9	1770	3,9	1770	9,3	1730	14,2	1600	17,2	1570	51	520-213-015
214	15,03:1	3,2	2940	6,3	2940	15,7	2840	22,4	2530	26,8	2450	72	520-214-015
215	15,1:1	5,4	4910	10,8	4910	25,4	4610	32,8	3730	38	3430	112	520-215-015
215	19,06:1	5,4	4910	10,8	4910	25,4	4610	32,8	3730	38	3430	112	520-215-020
216	15,1:1	8,6	7850	16,4	7500	37,3	6770	47,7	5400	55,9	5000	193	520-216-015
216	19,03:1	8,6	7850	16,4	7500	37,3	6770	47,7	5400	55,9	5000	193	520-216-020
217	14,7:1	13	11770	25,4	11430	56,7	10300					293	520-217-015
217	18,9:1	13	11770	25,4	11430	56,7	10300					293	520-217-020
218	15:1	20,5	18640	39,5	18050	91,7	16190					458	520-218-015
218	18,9:1	20,5	18640	39,5	18050	91,7	16190					458	520-218-020
219	15:1	29,8	26980	54,4	24330	108	19620					660	520-219-015
219	19:1	29,8	26980	54,4	24330	108	19620					660	520-219-020
316	61,34:1	8,6	7850	16,4	7500							197	520-316-060
317	60,04:1	13	11770	25,4	11430							307	520-317-060
318	61,43:1	20,5	18640	39,5	18050							520	520-318-060
319	60,56:1	29,8	26980	54,4	24330							690	520-319-060

Die WMH Aufsteckstirnradgetriebe sind direkt auf die Antriebswelle aufsteckbar und können vertikal oder horizontal montiert werden. Durch die genaue Bearbeitung werden optimale Laufruhe und Wirkungsgrade von 99% erreicht. Die Getriebe der Baugrößen 210 bis 219 sind zweistufig, die Baugrößen 316 bis 319 dreistufig.

Zahnräder: Einsatzstahl, einsatzgehärtet und geschliffen.

Gehäuse: Grauguß

The WMH Shaft mounted spur gear reducers can be fixed directly on the driven shaft and can be mounted in a horizontal or vertical position. The high quality gearing gives silent running and an efficiency of about 99%. The reducers from size 210 to 219 are double reduction, the sizes from 316 to 319 are triple reduction.
 spur gears: steel, case hardened and ground
 box: cast iron

Antriebsleistung bezogen zur Abtriebsdrehzahl n₂ | input power specific to the output speed n₂ [kW]

Abtriebsdrehmoment | output power [Nm]

Übersetzungsverhältnis | ratio i